

ÖLEVIA
By **SYNTAX**

User's Manual

LCD Multi-Media Display
LT42HVi



ÖLEVIA
By **SYNTAX**

Syntax Groups Corporation © 2005 All Rights Reserved
www.syntaxgroups.com
For Customer Service Call 888-SYNTAX-8

Table of Contents

Important Information	1
Important Safety Precautions	4
FCC Statement	8
Introducing the Syntax OLEVIA TV	9
Accessories	12
Installation And Connection Guide	15
Identifying Front Controls and Rear Inputs	16
-Descriptions of Input Types	17
-Connecting the TV's Power	18
Installation	19
-Connecting to an Antenna or Video Equipment with Antenna outlet	20
-Connecting to a VCR	21
-Connecting to an Audio Receiver/Home Theater System	22
-Connecting to a DVD Player with A/V or S Video Cables	23
-Connecting to a DVD Player with Component Cables	24
-Connecting to a Satellite Receiver or Cable Box with A/V Cables	25
-Connecting to a Satellite Receiver or Cable Box With Component Connectors	26
-Connecting to a PC with VGA, and a DVD Player with DVI/HDCP Cables	27
-Other Connections	28
Remote Control Guide	
-Regular Buttons	29
-Hotkeys Tutorial	30
-Hotkeys Description	31
Adjusting the On Screen Display (OSD)	
Introduction	35
VIDEO Adjusting TV Picture Settings	36
- Adjusting Picture Quality	36
- Video Settings	36
- To Adjust Settings	37
- Auto Setting : Return to Default Factory Settings	38
AUDIO Adjusting Sound Quality	39
- OSD Audio Settings : Equalizer 1	41
- OSD Audio Settings : Equalizer 2	41
- MTS System for Stereo TV	42
MISCELLANEOUS Adjusting Personal TV Settings	43
- Description of Settings	43
- Setting the Channels	44
- Personal Channel Preferences : Favorites	44
- Setting up the TV Timer	47
- Watching with Closed Caption	48
- TV OSD Languages	49
- Using the Parental Control Feature	49
- Parental Control	50
- Setting up Parental Control Password	53
- Factory Default Option	54
SCREEN Adjusting Screen Modes	55
- Changing the Screen Mode	55
- Picture in Picture (PIP)	56
- PIP Mode	58
- Split Screen	59
- Split Screen Mode	60
DTV:Adjusting DTV Settings	
Introduction to DTV	61
Channel Options	63
Caption Options	67
Setup Options	70
Lock Options	74
Specifications	85
Timing Mode for VGA and DVI	87
Pixels Policy	89
Glossary	90

Important information



Caution
Risk of electronic shock
Do not open



To reduce the risk of electronic shock, do not remove cover (or back).
No user-serviceable parts inside.
Refer service to qualified Repair Technician or Repair Center.



This symbol is intended to alert the user to the presence of important operating and maintenance (servicing) instructions in the literature accompanying the appliance.



This symbol is intended to alert the user to the presence of uninsulated "dangerous voltage" within the product's enclosure that may be of sufficient magnitude to constitute a risk of electric shock to persons..



Caution

Take caution when moving the product on a cart. Quick stops, excessive force, and uneven surfaces may cause the display unit and cart combination to overturn.

Caution

1. Read these instructions.
2. Keep these instructions.
3. Read all warnings.
4. Follow all instructions.
5. Do not use this apparatus near water.
6. Clean only with a dry cloth.
7. Do not block any ventilation openings. Install in accordance with the manufacturer's instructions.
8. Do not install near any heat source such as radiators, heat registers, stoves or other apparatus that produce heat.
9. Do not defeat the safety purpose of the polarized or grounding type plug. A polarized plug has type blades with one wide than the other. A grounding- type plug has two blades and a third grounding prong. The wide blade or third prong are provide for your safety. When the provide plug does not fit into your outlet, consult an electrician for replacement of the obsolete outlet.
10. Protect the power cord from being walked on or pinched particularly at plugs, convenience receptacles, and the point where they exit from the apparatus.
11. Only use attachment/accessories specified by the manufacturer.
12. Use only with a cart, stand, tripod, bracket or table specified by the manufacturer, or sold with the apparatus. When a cart is used, use caution when moving the cart/apparatus combination to avoid injury from tip-over.
13. Unplug this apparatus during lightning storms or when unused for long periods of time.

14. Refer all servicing to qualified service personal. Servicing is required when the apparatus has been damaged in any way, such as power supply cord or plug is damaged, liquid has been spilled or objects have fallen into the apparatus, the apparatus has been exposed to rain or moisture, does not operate normally, or have been dropped.
15. **WARNING:** To reduce to the risk of fire or electric shock, do not expose this apparatus to rain or moisture.
16. Apparatus shall not be exposed to dripping or splashing and no objects filled with liquids, such as vases, shall be placed on the apparatus.
17. Unplug the unit and inform the service center in case of abnormalities seen with regards to the operation of the unit.
18. **CAUTION:** Danger of explosion if battery is incorrectly replaced. Replace only with the same or equivalent type.
19. **WARNING:** To prevent injury, this apparatus must be securely attached to the floor/wall in accordance with the installation instructions.

Caution

These servicing instructions are for use by qualified service personnel only. To reduce the risk of electric shock, do not perform any servicing other than that contained in the operating instructions unless you are qualified to do so.

Caution

To prevent electric shock, match wide blade of plug to wide slot, fully insert.

Caution

This product satisfies FCC regulations when shielded cables and connectors are used to connect the unit to other equipment. Prevent electromagnetic interference from electrical appliances such as radios and televisions. Please use shielded cables and connectors for connections.

Warning

FCC Regulations state that any unauthorized changes or modifications to this equipment not expressly approved by the manufacturer could void the user's authority to operate this equipment.

Notification

This equipment has been tested and found to comply with the limits for a Class B digital device pursuant to Part 15 of the FCC Rules. These limits are designed to provide reasonable protection against harmful interference in a residential installation. This equipment generates, uses and can radiate radio frequency energy and, if not installed and used in accordance with the instructions, may cause harmful interference with radio communications. However, there is no guarantee that interference will not occur in a particular installation. If this equipment does cause harmful interference to radio or television reception, which can be determined by turning the equipment off and on, the user is encouraged to try to correct the interference by one or more of the following measures:

- Reorient or relocate the receiving antennas.
- Increase the separation between equipment and receiver.
- Connect the equipment into an outlet on a circuit different from that to which the receiver is connected.
- Consult the dealer or an experienced radio/TV technician for help.

You are cautioned that any changes or modifications not expressly approved in this manual could void your authority to operate this equipment.

Caution

The following appliance(s) for use only with the following TV STAND or WALL-HANGING RACK UNIT as mentioned in user manual or operating instructions. Use with other TV STAND or WALL-HANGING RACK UNIT is capable of resulting in instability causing possible injury.

Caution

Sufficient expertise is required for installing the specified product. Be sure to subcontract the installation to a local dealer or contractor and pay adequate attention to safety during installation.

Important Safety Precautions

Before using your TV, please read these instructions completely, and keep this manual for future reference. Carefully observe and comply with all warning, cautions and instructions placed on the set or described in the operating instructions or service manual.

WARNING

To guard against injury, the following basic safety precautions should be observed in the installation, use and servicing of the set.

Follow operating instructions

All operating instructions must be followed.

Power Sources

This set should be operated only from the type of power source indicated on the serial/model plate or specification label. If you are not sure of the type of electrical power supplied to your home, consult your dealer or local power company. For other units designed to operate on batteries or another power source, refer to the operating instructions.

Grounding or Polarization

This set is equipped with a polarized AC power cord plug (a plug having one blade wider than the other), or with a three-wire grounding type plug (a plug having a third pin for grounding).

Polarized AC Power Cord Plug

The plug will fit into the power outlet only one way. This is a safety feature. If you are unable to insert the plug fully into the outlet, try reversing the plug. If the plug still fails to fit, contact your electrician to have a suitable outlet installed. Do not defeat the purpose of the polarized plug by forcing it in.

Wall Outlet

Do not use a poor fitting outlet. Insert the plug fully into the outlet. If it is loose, it may cause arcing and result in fire. Contact your electrician to have the outlet changed.

Wiring

Unplug AC power cord when wiring cables. Be sure to unplug the AC power cord for your safety, when hooking up.

AC Cord Protection

Do not allow anything to rest on or roll over the AC cord, and do not place the set where the power cord is subject to wear or abuse. The AC cords must be routed properly to prevent people from stepping on them or objects from resting on them. Check the cords at the plugs and unit display.

Overloading

Do not overload wall outlets, extension cords or convenience receptacles beyond their capacity, since this can result in fire or electric shock.

Attachments

Do not use attachments not recommended by the manufacturer. Use of inadequate attachments may result in accidents to nearby people or to the unit.

Keep away from water and moisture

Do not place the display in areas where moisture is present or where the unit may get wet such as bath-rooms, kitchen, pool area or in a wet basement.

Keep away from heat sources

Keep the display unit away from heat sources such as radiators, heaters, stoves and other heat-generating products.

The Liquid Crystal Panel Used in this Product is Made of Glass

Do not hit the panel. Be careful to prevent from getting hurt by broken glass pieces in case the panel breaks.

Cleaning AC Plug

Clean the AC plug regularly. If the plug is covered with dust and it picks up moisture, its insulation may deteriorate and result in fire. Unplug the AC power plug and clean it regularly.

Cleaning the Display

Remember to unplug the AC cord from the AC outlet before cleaning the display unit. And do not use liquid or aerosol cleaners to clean the display.

- Minimize contact with the LCD screen surface since the special coating applied may be affected. Use a dry soft cloth when removing dust from the screen.
- Do not use alcohol, benzine, thinner, etc., as it may damage the coating or cause LCD screen deterioration.
- Do not allow the LCD screen to come in contact with volatile compounds such as insecticide. Also never let LCD screen come in contact with rubber or plastic products for an extended period of time. This type of contact may damage the coating, or cause the LCD screen to deteriorate.

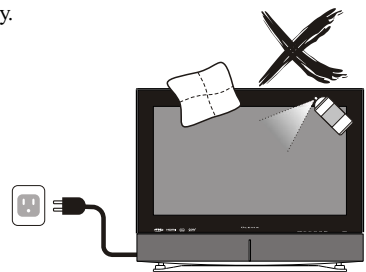

Stand

Do not place the set on an unstable care, stand, table of shelf. The set may fall, causing serious injury to a child or an adult and serious damage to the set. Use only a cart or stand for the specific model of TV. No part of the TV set should overhang any edge of the TV card or stand; any overhanging edge is a safety hazard.

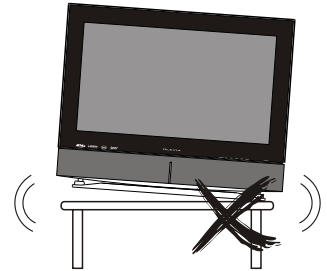

Accessories

Secure the display unit from falling down. If the display unit is not secured properly, it may fall and cause injury. Take measures against it using a stand or other apparatus on the floor wall in the specified manner, referring to the operating instructions supplied with your stand.

Ventilation

The slots and openings in the media receiver unit and display unit are provided for necessary ventilation. To ensure reliable operation of the set, and to protect it from overheating, these slots and openings must never be blocked or covered. Unless proper ventilation is provided, the unit may gather dust and get dirty. For proper ventilation, observe the following:

- Do no install the unit turned backwards or sideways.
- Do not install the unit turned over or upside down.
- Do not cover or block these vents and openings located on the top and back of the display. Inadequate ventilation may cause overheating and shorten the lifespan of the display.
- Do not place in an enclosed area such as a built-in shelf, unless proper ventilation is provided or the manufacturer's instructions are followed.
- Keep the distance of 10cm minimum between the display unit and wall.
- Do no place set near or over radiator or heat register, or where it is exposed to direct sunlight.
- Never install the display unit as indicated in the picture on the right.

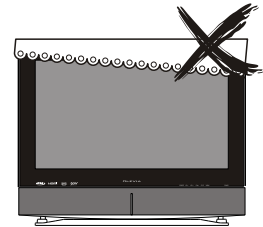

Air circulation is blocked

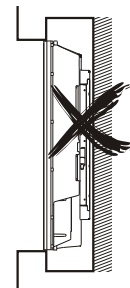

Air circulation is not blocked

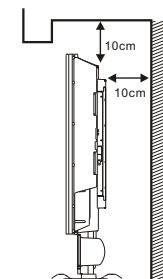

Transporting and Carrying the Display

Carrying the set requires two or more people. If you carry the set in a manner other than that specified, it may drop and cause serious injury. Be sure two or more people carry the set. When transporting, do not subject the set to shocks or vibration of excessive force. The set may fall and become damaged or cause serious injury.

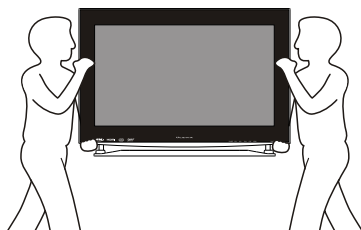

Never insert objects or spill liquid into the display unit

Never insert any object into the display unit through openings or spill liquid on the display unit. High voltage flows in the display unit, and inserting an object can cause electric shock and/or short internal parts.



Outdoors Use

Do not install this unit outdoors. If the unit is exposed to rain, it may result in fire or electric shock. If the unit is exposed to direct sunlight, the unit may heat up and it may damage the unit.

Service

Damage Requiring Service (Repair)

When the unit displays an abnormal condition, any noticeable abnormality in the display unit indicates that the unit needs servicing.

Unplug the set from the wall outlet and AC cord, and refer servicing to qualified service personnel under the following conditions:

- When power cord or plug is damaged or frayed
- If liquid has been spilled into the set
- If the set has been exposed to rain or water
- If the set has been subject to excessive shock by being dropped, or the cabinet has been damaged
- If the set does not operate normally when following the operating instructions. Adjust only those controls that are specified in the operating instructions. Improper adjustment of other controls may result in damage and will often require extensive work by a qualified technician to restore the set to normal operation.
- When the set exhibits a distinct change in performance, it indicates a need for service.

Replacement Parts

In case the display unit needs replacement parts, make sure that the service technician uses replacement parts specified by the manufacturer, or those with the same characteristics and performance as the original parts. Be sure the technician certifies in writing that he/she has used the specified replacement parts. Use of unauthorized parts can result in fire, electric shock and/or other hazards.

Servicing

Do not attempt to service the display unit yourself. Removing covers expose you to high voltage and other dangerous conditions. Request a qualified service technician to perform the service.

Safety Checks

Upon completion of service or maintenance, request the service technician to perform safety checks to ensure that the display unit is in proper operating condition.

Environment

No operating temperature is specified.

FCC Statement

FCC notice

This equipment has been tested and found to comply with the limits for a Class B digital device, pursuant to part 15 of the FCC Rules. These limits are designed to provide reasonable protection against harmful interference in a residential installation. This equipment generates, uses and can radiate radio frequency energy and, if not installed and used in accordance with the instructions, may cause harmful interference to radio communications. However, there is no guarantee that interference will not occur in a particular installation. If this equipment does cause harmful interference to radio or television reception, which can be determined by turning the equipment off and on, the user is encouraged to try to correct the interference by one or more of the following measures:

- 1.Reorient or relocate the receiving antenna.
- 2.Increase the separation between the equipment and receiver.
- 3.Connect the equipment into an outlet on a circuit different from that to which the receiver is connected.
- 4.Consult the dealer or an experienced radio/TV technician for help.

Modifications not expressly approved by the manufacturer could void the user's authority to operated the equipment under FCC rules. This device complies with part 15 of the FCC Rules. Operation is subject to the following two conditions:

- 1.This device may not cause harmful interference.
- 2.This device must accept any interference received, including interference that may cause undesired operation.

For Canadian model

This Class B digital apparatus complies with Canadian ICES-003.

Approval



Introducing the Syntax™ OLEVIA™ TV

Welcome!

Thank you for purchasing a Syntax™ OLEVIA™ LCD TV. This manual is to be used with the following model:

LT42HVi

This manual is designed to help you through setting up and operating your LCD TV as quickly as possible. The model and serial numbers are on the back cover of your TV. Write these numbers in the space provided in this manual for your records. Please read all the safety and operating instructions carefully, and keep this manual for future reference.

Owner's Record

The model and serial numbers are located at the rear of the display unit, or on the side of the media receiver unit on the cartons (white label). Record these numbers in the spaces provided below. Refer to them whenever you call upon your Syntax Groups Corporation or local dealer regarding this product.

Model No. _____

Serial No. _____

Package Contents

- Syntax™ OLEVIA™ display unit
- Remote Control
- 1 AC power cord
- Operating Instructions
- Quick Start Guide
- Warranty Card

These items are all you need to set up and operate the TV in its basic configuration.

Note: Most components (VCRs, DVD players, etc.) come with the necessary cables to connect them. If you want to set up a complex system, you may need to buy extra cables, connectors, etc. Be sure to have these on hand before you start to connect your system.

Syntax™ OLEVIA™ LCD TV includes many features you will enjoy throughout the usage of your TV. These highlighted features include:

Fully Integrated HDTV (High Definition TV):

HDTV delivers a stunning picture far beyond the quality of standard televisions. These programs offer crystal clear video with amazing detail played with enhanced audio quality of digital television programs. You can enjoy better sound and picture in movies, prime time TV shows, and other HD broadcasts in dynamic television settings through cable, satellite or even free broadcasts over the air.



IDEA (Innovative Digitally Enhanced Architecture):

Syntax's™ proprietary digital video processing technology, a highly integrated System-On-a-Chip, delivers an exceptional solution to digital display complexities commonly associated with color, contrast, sharpness, motion, noise and audio lip-sync. It's a suite of built-in and user-selectable video/audio features that deliver precise colors, sharp resolutions and audio synchronization through its advanced Digital Sound Processor (DSP) technology.



IDEA includes a variety of preprogrammed and user-selectable image enhancements including:

- Dynamic Brightness and Contrast
- Pure Edge Enhancement
- Dynamic Noise Reduction
- Black Level Extender
- White Peak Limiter
- Advanced Digital Sound Processor
- Clarity of audio synchronization of built in sound technology

Super IPS Technology (Super In-Plane Switching Technology):

Superior panel technology provides the best image performance for LCD TVs with higher color saturation, widest viewing angles, sharpest images and best response times while reducing to the minimal amount, color shift and distortion at any angle.



ATSC Digital Tuning System:

Enables the television set to receive digital ATSC signals, as well as digital terrestrial broadcasts for a wide variety of channels and shows.



HDMI (High Digital Multimedia Interface):

The next generation of DVI. Provides the best interface between a DVD player and compatible products such as digital television (DTV) for uncompressed digital audio/video connections. When matched with a Syntax OLEVIA TV, multi-channel digital audio signals, uncompressed DVI digital video™ and intercommunication between high multimedia interfaces are combined through a single interconnecting cable.



Optional Convertible Speaker Set (Optional):

Syntax™ OLEVIA™ LT42HVi's most innovative element gives you an option to personalize the TV and speaker system. Featuring a speaker mounting system powered by 25-watt stereo amplifier, the panel's speaker can be mounted vertically on each side of the TV, horizontally at the base of the TV, or completely removed and placed in a drawer for safekeeping if you desire to connect the TV to a separate home theater system. A newly designed stand is detachable if you want to wall mount the Olevia.



1200:1 Dynamic Contrast Ratio:

Displays an adaptive contrast enhancer to the brightness and darkness of images, pictures and scenes. Featuring a dynamic iris optical system that constantly adjusts to each image on the screen in "real time", Syntax™ OLEVIA™ TV's are dynamically enhanced with the raw frame contrast of the LCD panel.

Favorite Channels:

Allows you to preview and select from 16 of your favorite channels
Parental Control: V-Chip technology allows parents to block unsuitable programming from younger viewers.

Wide Screen Mode:

Enjoy watching conventional 4:3 aspect ratio broadcasts in wide screen (16:9) mode.

Sleek and Slim Cabinet Design:

Our 42" wide LCD TV models have a slim profile and a depth advantage that allows them to fit into almost any home environment.

Accessories

Supplied accessories

Remote control & batteries (AAA x 2)



User manual booklet x 1

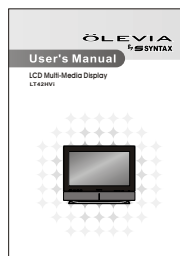

QSG x 1



Power cord x 1



Optional accessories

AV cable with RCA connector



S-video cable



DVI cable



Audio cable with RCA connector



Component cable with RCA connector



VGA cable (D-Sub 15 male) x 1



HDMI to HDMI cable x 1



Wall mount set

Model# WM-21D

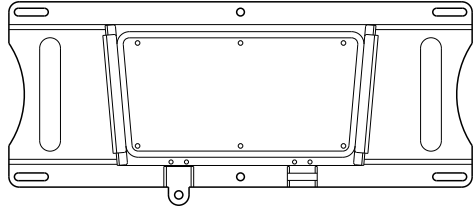

1. Before using the wall mount, please read manual of wall mount and following assembly guide.
2. For safety purposes, please purchase a wall mount which can bear the LCD TV weight. The current model SYNTAX recommends is WM-21D.
3. Follow the exact installation instruction. This is only for your reference.
4. Please consult authorized service personnel for the installation of wall mount.

Audio cable with stereo mini jack

Use the proper cable for the device.



(Stereo mini jack cable)



(Stereo mini jack to RCA cable)

Removable Speakers (Optional)

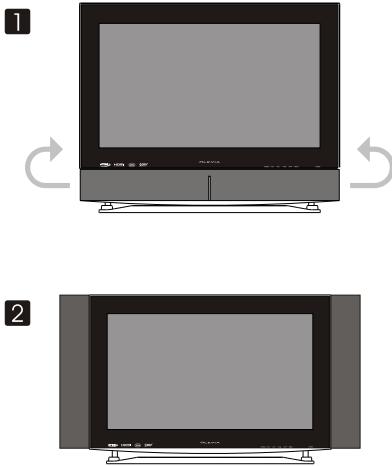

This is an optional function for the LT42HVi TV. Speakers can be removed from the bottom of the TV and mounted on each side of the TV. Speakers may be setup according to personal preference.

General Instructions

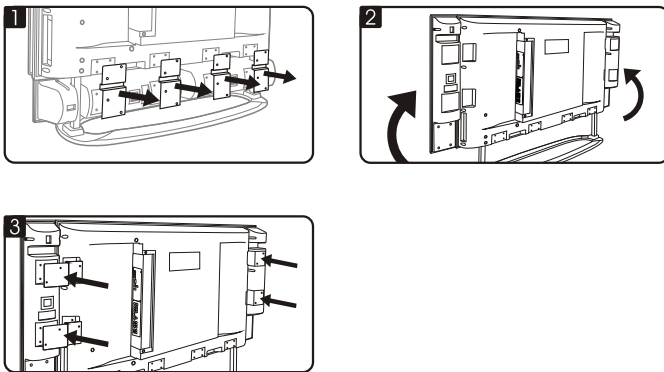

Detailed instructions included in separate guide.

TV Installation and Connection Guide

Identifying Front and Rear Panels

Front Panel

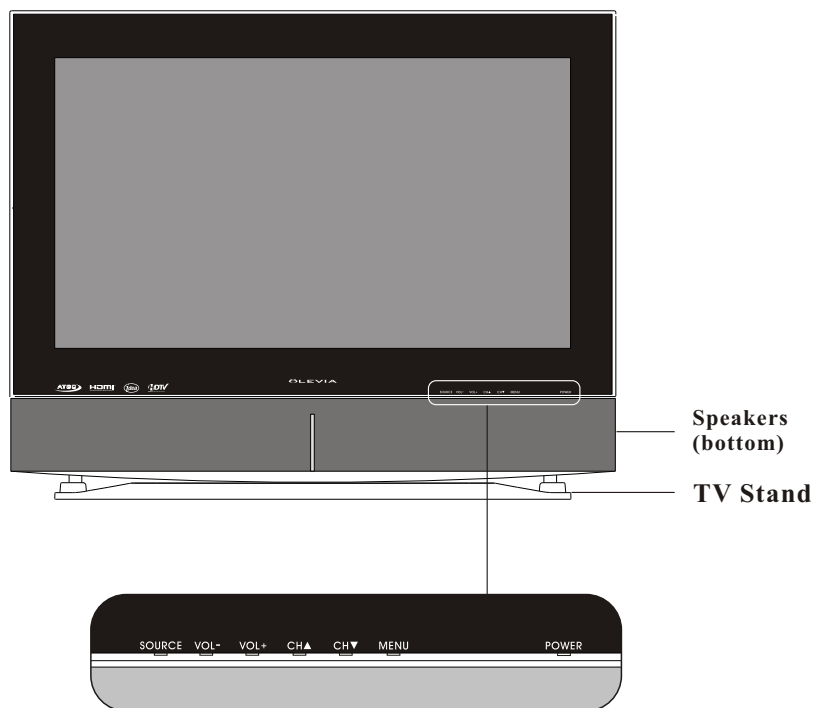

POWER Turns display on/off

MENU Displays the On Screen Display (OSD) menu. In OSD menu, press it to return to pre-phase

CH▲/CH▼ Adjusts Channel. In the OSD menu, both keys are used to navigate with in menu.

VOL+/VOL- Adjusts volume. In OSD menu, both key are used to navigate within menu. Vol+ is used to select the highlighted option.

SOURCE Press to switch the input sources

Speakers (bottom) Outputs audio signal. The speakers can be detached from bottom to Left and Right positions. For details and assembling instructions, please see separate instruction manual.

TV Stand Table top stand is adjustable with two settings for your preferred height. For details and assembling instructions, please see separate instruction manual.

Identifying Front and Rear Connectors

Rear Panel

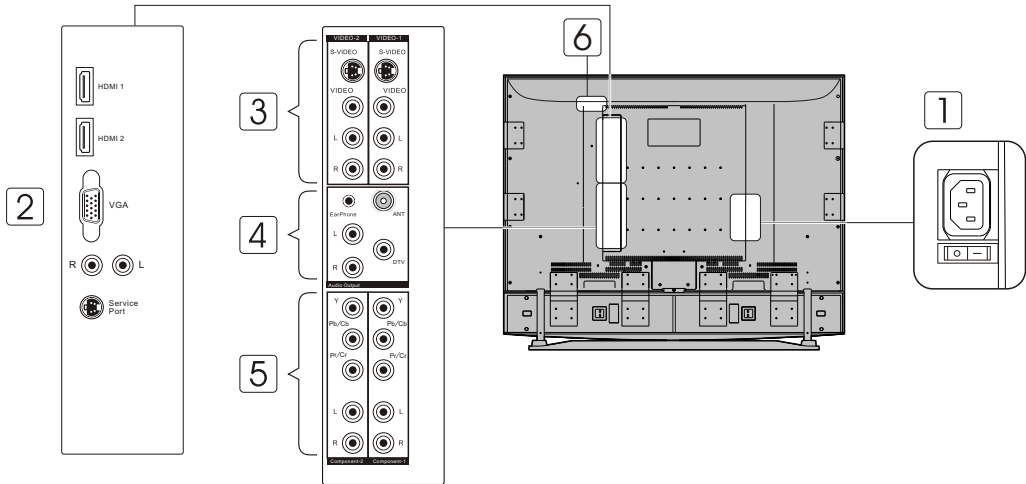

1 AC IN power cord connects here.

2 HDMI 1/ HDMI 2 and VGA Port This display includes 2 HDMI inputs which can receive digital video signals through the interface for the display of high quality digital video signals. Both HDMI ports are HDCP (High Bandwidth Digital Content Protection) compliant and is fully compatible with video equipment that features the HDCP function. The VGA input can be used for analog RGB signals from a HD Receiver or personal computer. Resolutions supported are VGA, SVGA, XGA and WXGA. The HDMI and VGA ports share the one Audio L/R inputs.

Service Port is reserved for manufacturer use. Incorrect use may damage the Display.

3 Video 1,2 These inputs can be used for the connection of a VCR, Super VHS (S-VHS) VCR, DVD player, or other video devices to the TV. There is a Video and an S-Video input for Video 1 and video 2. When both inputs are used simultaneously on Video 1, only the S-Video input will be recognized. Same behavior for Video 2. The display will automatically detect the input being used.

NOTE: The S-Video input has a better quality of picture than a composite Video signal.

4 Audio Out The Audio Output sends the TV's connected audio signals to an A/V receiver or other equipment. Display features a R/L stereo .

Antenna (ANT) Antenna receives signals from VHF/ UHF antennas or a cable system.

DTV Digital Audio Cable Input

The DTV input receives digital audio signals from an ATSC digital receiver and broadcasts programs on VHF/UHF TV signals.

5 Component 1, 2 These inputs can be used for the connection of A/V equipment with component video outputs, such as a DVD player, Digital Satellite Receiver, or compatible Video Game System.

6 AV-light lights up during connection process for user viewing assistance.

To Activate: Press "Source" & "Vol+" simultaneously to turn AV-light on. It will automatically turn off after 60 seconds.

Descriptions of Connector Types

You may find it necessary to use some of the following connector types during setup.

75-ohm coaxial cable Used for TV cable connection .



S-Video Cable High quality video cable for enhanced picture quality.



Audio/Video Cable

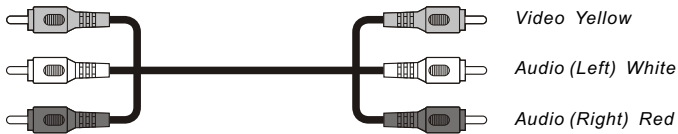

Some DVD players are equipped with the following three video connectors:

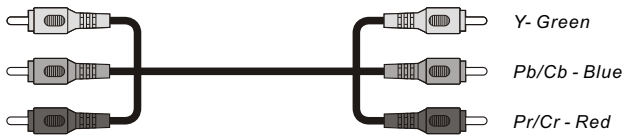

HDMI to HDMI cable



HDMI to DVI cable



Connecting the Power Cord

Complete other connections prior to connecting the power cord:

1. Connect the power cord to the AC IN connector of the TV

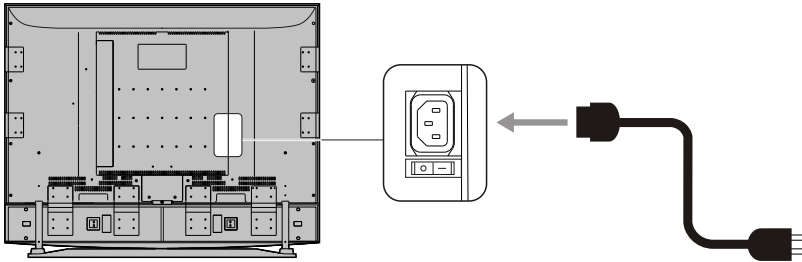

2. Connect the other end of the power cord to the wall outlet.

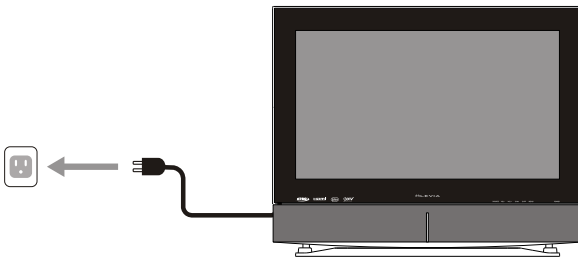

AV Light: Custom Lighting while Connecting the TV

An AV-Light is located in the rear panel above Video 1 and Video 2.

To activate the AV-Light, simultaneously press the Source and Vol+ buttons on the front panel, to turn the AV-Light on. The AV-Light will remain on for 1 minute.

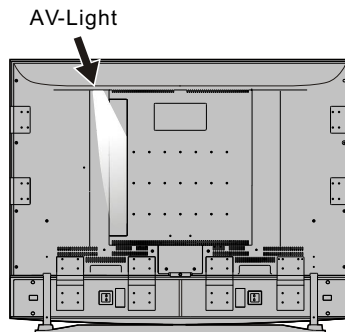

Keep Your TV Cable Cords Organized

You can organize the display interface cables in order to minimize cord tangling. On the rear panel of the TV, located on the mid-left backside, is a Cable Fastener for bundling cable connectors together and keeping them organized.

Installation

In the following pages, you will find directions on how to install your tv and choice of video equipment.

- **Connecting to an Antenna or Video Equipment with Antenna outlet**
- **Connecting to a VCR**
- **Connecting to an Audio Receiver/Home Theater System**
- **Connecting to a DVD Player with A/V or S Video Cables**
- **Connecting to a DVD Player with Component Cables**
- **Connecting to a Satellite Receiver or Cable Box with A/V Cables**
- **Connecting to a Satellite Receiver or Cable Box With Component Connectors**
- **Connecting to a PC with VGA, and a DVD Player with HDMI/HDCP Cables**
- **Other Connections**
- **Tear the outer protection film out of the TV**

End-user should tear off of the outer protection film out of the TV from the tag attached on the upper left corner or the lower right corner.



Connecting to an Antenna or Video Equipment with Antenna outlet

⚠️ Disconnect all power sources before making any connection.

1. Connect a 75-ohm coaxial cable onto the ANT input on the back of the TV's right side panel.

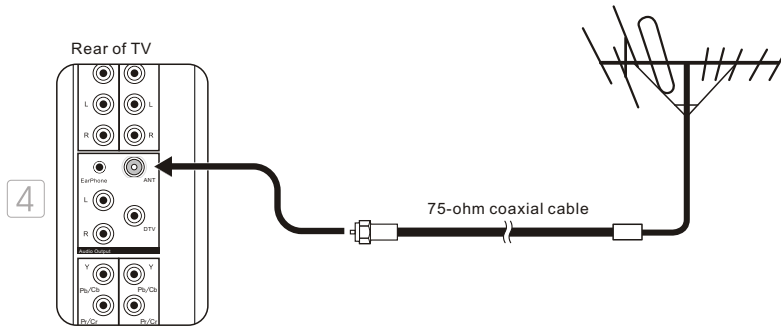

If connecting to Video Equipment with Antenna outlet

1. Using a 75-ohm coaxial cable (or choice of Antenna Cable), connect the cable box's OUT jack to the TV's ANT jack (RF Terminal).

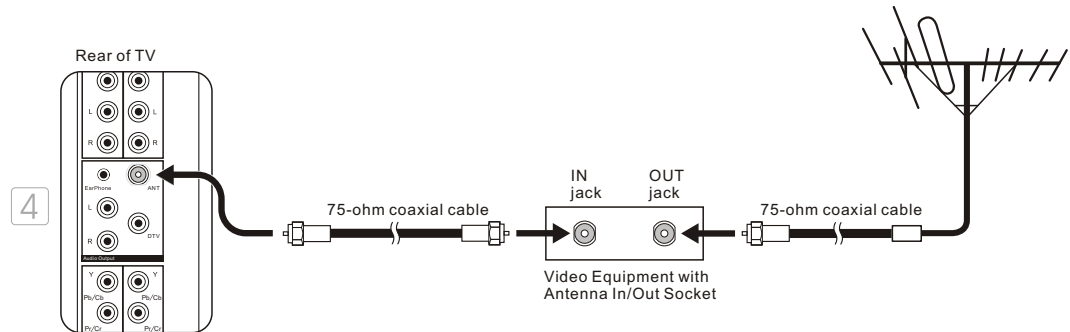

Connecting to a VCR

⚠ Disconnect all power sources before making any connections.

Use this hookup if you subscribe to a cable TV system that does not require a cable box.

- Using A/V cable and S-Video cables, connect the VCR's Audio and S Video OUT jacks to the TV's Audio and S-Video In jacks.

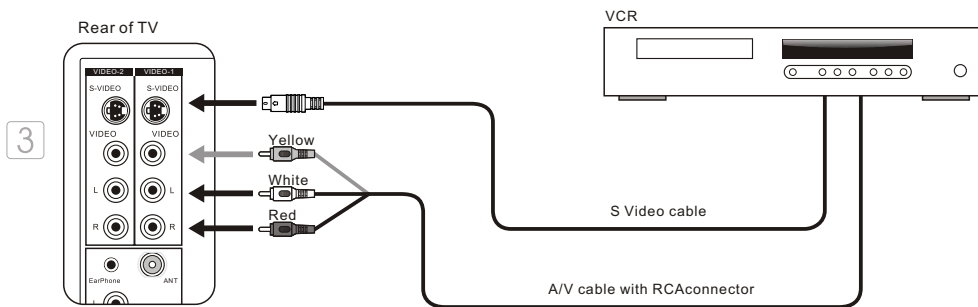

When Connecting both Video IN or S-Video IN

Note: When you connect video equipment to both the same Video and S-Video input jacks, display will automatically select S-Video first. To view Video signal, please disconnect the S-Video jack or turn off the S-Video signal on the video equipment.

S-Video is strongly recommended for use if your VCR or video equipment has it. S-Video input has a better quality of picture than a composite Video signal.

Note: You can also use the Video 2 jacks located on the TV rear, or Video 3 located on the right side of the display to connect additional video equipment.

Connecting to an Audio Receiver / Home Theater System

⚠ Disconnect all power sources before making any connections.

1. Using an audio cable, connect the TV's audio OUT jack to the audio receiver's audio IN or AUX IN jacks.

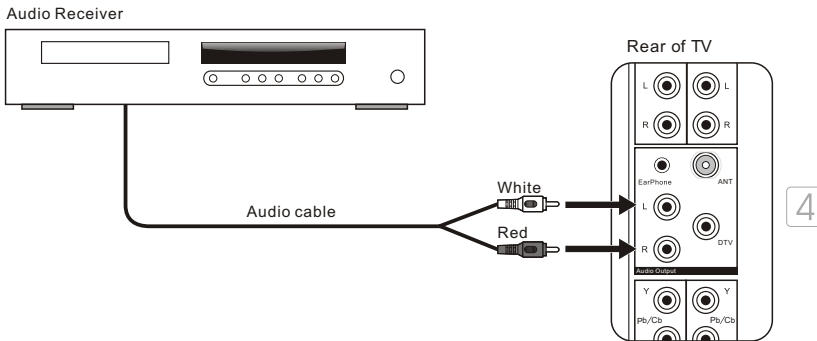

Note: When connecting an Audio output signal, an external Audio amplifier is necessary to amplify the signal for external speakers.

Note: If the audio out is hooked up to a home theatre sound system, please disable the audio in the OSD by selecting off in audio section . Volume adjustment must be made on the home theatre receiver. By not disabling the TV's speaker it could damage the speakers or TV itself.

Connecting to a DVD Player with A/V or S Video Cables

⚠ Disconnect all power sources before making any connections.

Use this hookup if your DVD player does not have component (Y, Pb, Pr) jacks.

Note: If your DVD player has component video output connectors, for best picture quality, use the connection described for *Connecting to a DVD Player With Component Connectors.* (See page.17)

1. Using an A/V cable, connect the DVD player's Audio OUT jacks to the TV's Audio IN jacks.
2. Using an SVideo Cable, connect the DVD player's S Video OUT jack to the TV's S Video IN jack.

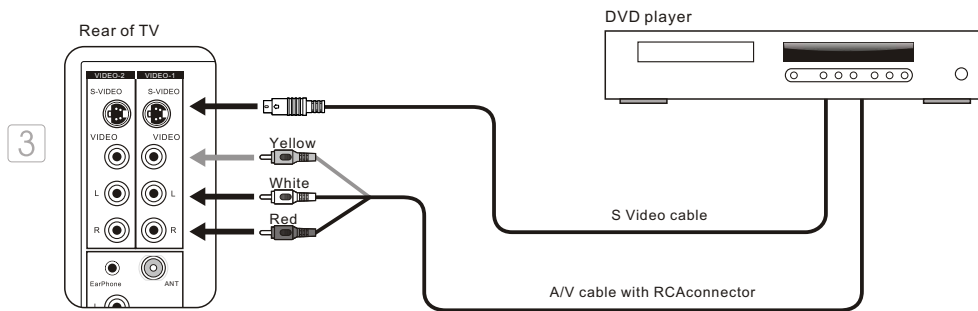

Note: When you connect video equipment to both the same Video and S-Video input jacks, the display will automatically select S-Video first. To view Video signal, please disconnect the S-Video jack or turn off the Video signal on the video equipment.

S-Video is strongly recommended for use if your VCR or video equipment has it. S-Video input has better quality of picture than a composite Video signal.

Note: You can also use the Video 2 jacks located on the TV rear, or Video 3 located on the right side of the display to connect additional video equipment.

Connecting to a DVD Player With Component Cables

⚠ Disconnect all power sources before making any connections.

Use this hookup if your DVD Player has component (Y, Pb, Pr) jacks.

1. Using a component video cable, connect the DVD Player's Y, Pb and Pr jacks to the Y, Pb and Pr jacks on the TV.

Colors on Component Video connectors:

Y: Green

Pb (also identified as Cb, CB or B-Y): Blue

Pr (also identified as Cr, CR or R-Y): Red

Note: The Y, Pb and Pr jacks on your DVD player are sometimes labeled as Y, Cb and Cr, or B-Y and R-Y. If so, connect the cables to the matching colors.

2. Using an Audio cable, connect the DVD player's Audio OUT jacks to the TV's Audio in jacks.

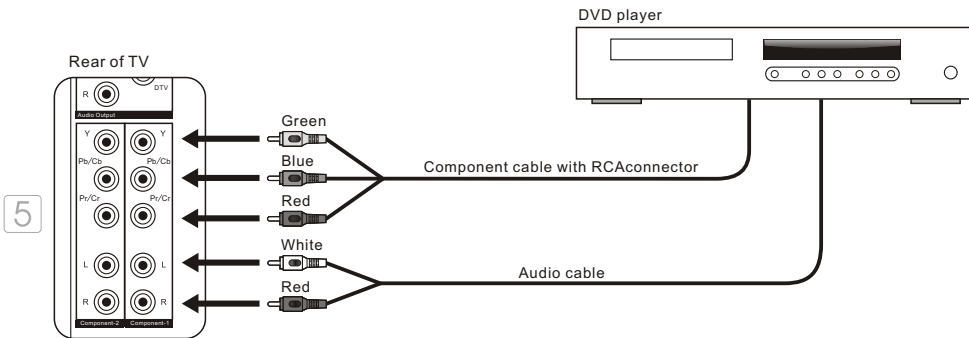

Note: The Y, Pb and Pr jacks do not provide audio, so audio cables must be connected to provide sound.

Note: The YPbPr connection provides the best quality of video signal compared to AV (Composite) and S-Video connection.

Connecting to a Satellite Receiver or Cable Box with A/V Connectors

⚠ Disconnect all power sources before making any connections.

1. Using Audio and S Video cables, connect the satellite receiver's Audio and S Video OUT jacks to the TV Audio and S Video IN jacks.
2. Connect a 75-ohm coaxial cable from your cable or antenna to the TV Ant (Antenna) jack.

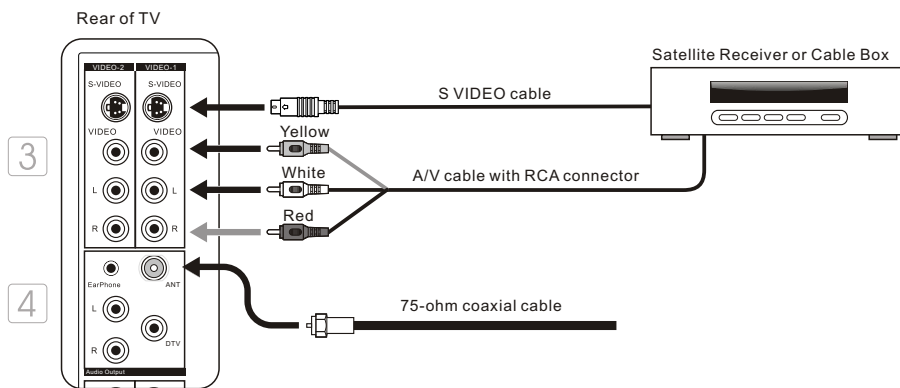

Note: When you connect video equipment to both the same Video and S Video input jacks, display will automatically select S Video first. To view S Video signal, please disconnect Video jack or turn off the Video signal on the video equipment.

S-Video is strongly recommended for use if your VCR or video equipment has it because S-Video input has better quality of picture than a composite Video signal.

Note: You can also use the Video 2 jacks located on the TV rear, or Video 3 located on the right side of the display to connect additional video equipment.

Connecting to a Satellite Receiver or Cable Box With Component Connectors

⚠ Disconnect all power sources before making any connections.

Use this hookup if your Satellite Receiver or Cable Box has component (Y, Pb, Pr) jacks.

1. Using a component video cable, connect the Satellite Receiver or Cable Boxes' Y, Pb and Pr jacks to the Y, Pb and Pr jacks on the TV.

Colors on Component Video connectors:

Y: Green

Pb (also identified as Cb, CB or B-Y): Blue

Pr (also identified as Cr, CR or R-Y): Red

Note: The Y, Pb and Pr jacks on your Satellite Receiver or Cable Box are sometimes labelled as Y, Cb and Cr, or B-Y and R-Y. If so, connect the cables to the matching colors.

2. Using an Audio cable, connect the Satellite Receiver or Cable Boxes' Audio OUT jacks to the TV's Audio in jacks.

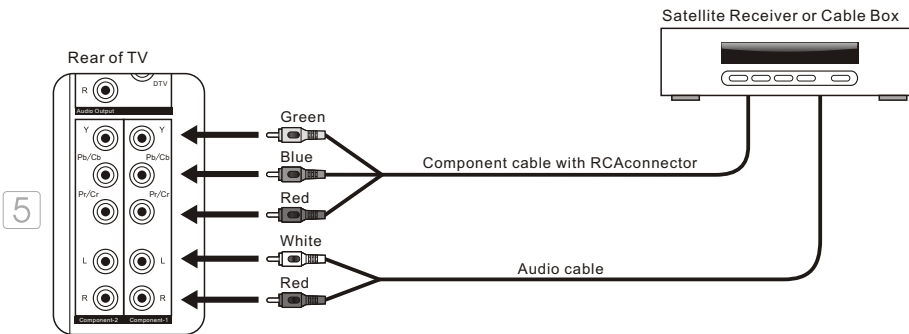

Note: The Y, Pb and Pr jacks do not provide audio, so audio cables must be connected to provide sound.

Note: The YPbPr connection provides the best quality of video signal compared to AV (composite) and S-Video connection.

Connecting to a PC with VGA Connector

⚠ Disconnect all power sources before making any connections.

1. Using a D-Sub 15 pin cable, connect the VGA output terminal of the PC to the TV's VGA signal input terminal.
2. You may need to use a Stereo mini jack to RCA L/R connectors to receive audio.

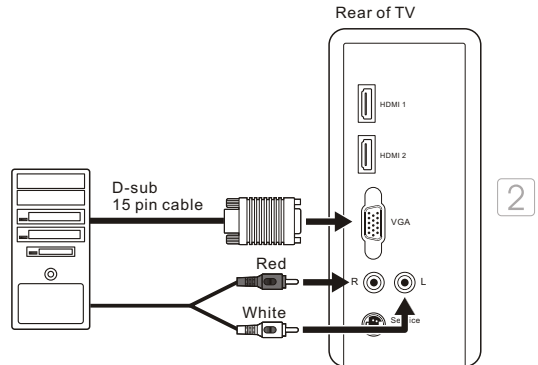

Connecting to a DVD Player or HD-Receiver with a HDMI Cable

⚠ Disconnect all power sources before making any connections.

1. Using a HDMI cable, connect the DVD's HDMI output terminal to one of the TV's HDMI-HDCP input terminals.
2. Using an Audio cable, connect the DVD's Audio OUT jacks to the TV's Audio IN jacks.

Note: HDCP is a copy protected digital connection that receives digital video signals from equipment with a HDMI output that features the HDCP function. HDMI allows the transfer of digital uncompressed data to the TV. This connection is superior when compared to the Component, S Video or AV (composite) connections.

Note: HDMI signal is purely digital and provides a crystal clear technology better than component, S-Video or Video connections. It is strongly recommended to use this connection if you have this function on your equipment.

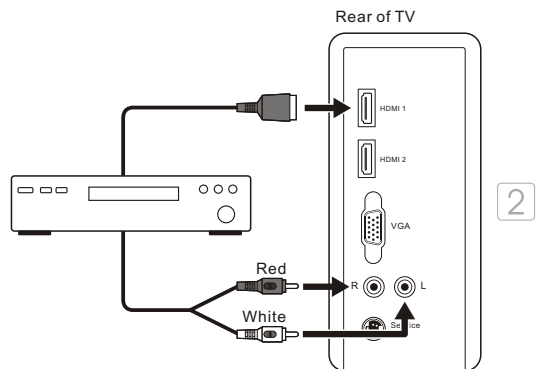

Other Connections

⚠ Disconnect all power sources before making any connections.

See setup instructions for: Connecting to an Audio Receiver on page 15.

Speakers Outputs

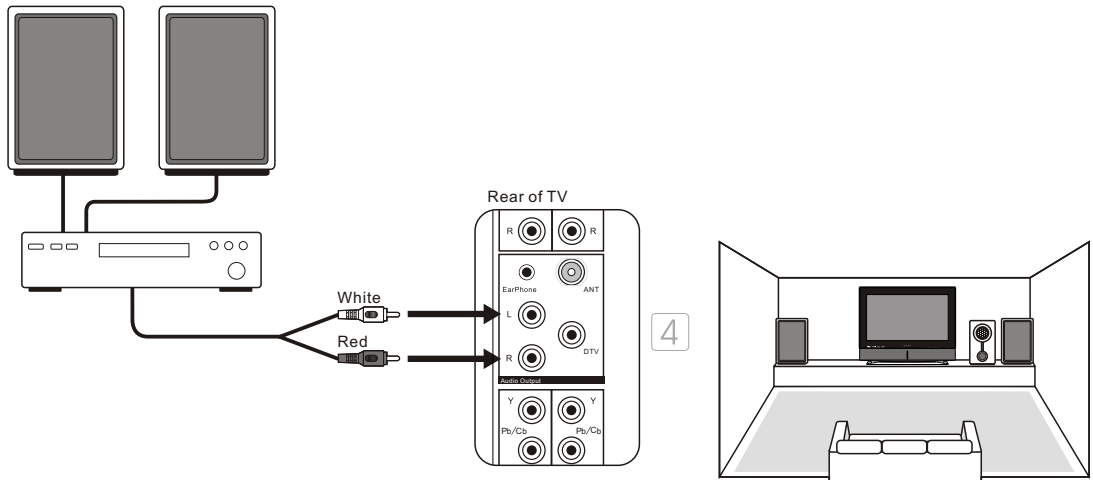

Headphone Set

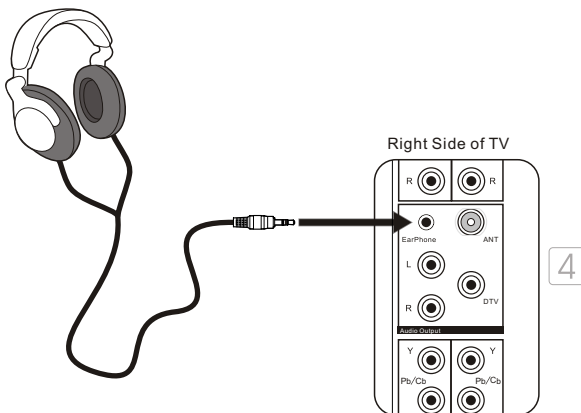

Note: When headphone is plugged in the speaker will turn into mute mode.

Remote Control Guide

Remote Function Keys & Description

Regular Buttons

- 1 MUTE** Press to mute the sound.
- 2 NUMBER BUTTONS** Press the number buttons to select channels on the display.
- 3 CH RTN (Channel return)** Press to return the previous-channel.
- 4 MTS** Press to select from SAP, Mono or Stereo mode
- 5 VOL+ / VOL -** Press to adjust the volume.
- 6 FAVORITE** Press to select favorite channels. Can be preset in OSD Menu.
- 7 DISPLAY** Press to display the information of current channel number and time.
- 8 POWER** Press to turn display on/off.
- 9 -** Press to select sub-channel.
- 10 MENU** Press to activate or close the On Screen Display menu. In OSD Menu, acts as a cancel button while navigating through the OSD.
- 11 CH + / CH-** Press to adjust channel up and channel down.
- 12 ENTER** Press to enter the channel number, highlighted menu or submenu item.
- 13 SOURCE** Press to show the source input from TV, Video 1, Video 2, VGA, Component 1, Component 2, HDMI 1, HDMI 2, DTV and Cardreader (optional).
- 14 EPG** Press to display the Program Guide Window.
- 15 Hotkeys** Press to directly access certain Shortcut TV functions..

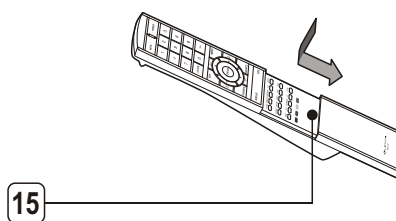
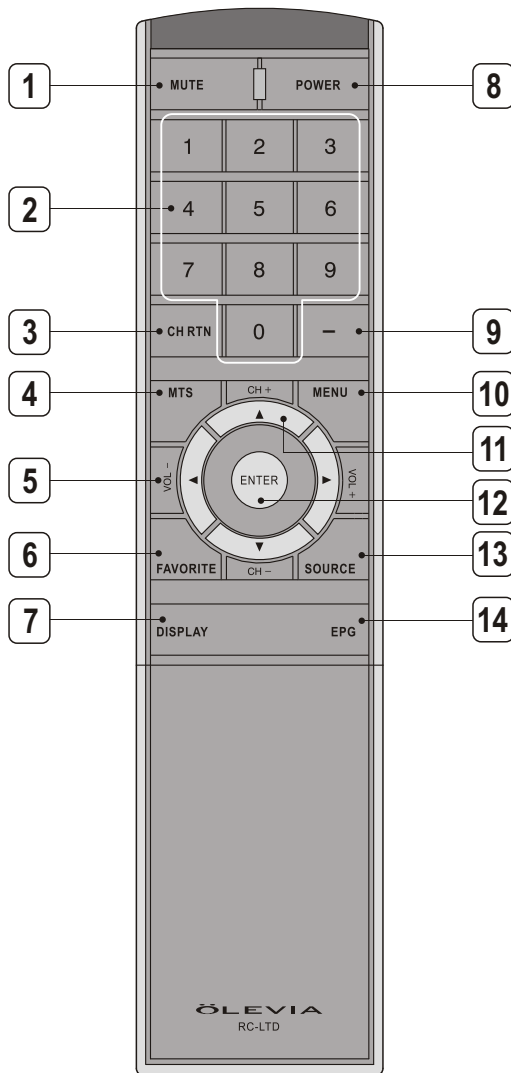

Hot Keys Tutorial

The remote control contains 15 additional "Hotkeys" that represent direct access to a certain function on your TV. Hotkeys enable you to directly change the setting to your preference without having to navigate through the OSD (On Screen Display) Menu.

How to use your Hot Keys

HOT KEY FUNCTION

TV/VIDEO Press to switch between TV and source as Video 1 and Video 2 Mode.

HDMI/VGA Press to switch to HDMI or VGA Mode.

COMPONENT Press to switch between Component 1 and Component 2

C.R. (Optional function currently unavailable)

FREEZE Press to freeze the picture. Press again to unfreeze the picture.

V.FORMAT This hotkey enables you to change TV picture resolution.

CAPTURE (Optional function currently unavailable)

ASPECT Press to change the aspect ratio (Full, 4:3, 16:9, Panoramic) and letterbox modes.

VIEW Press to select and program PIP, POP3, Split Screen or POP12 viewing options.

SWAP Press to select TV channels between main and sub screen. (This is function only in the PIP and Split Screen modes.)

ZOOM Press to select zoom function (2X, 4X, 8X, 16X, 32X, 1/2, 1/4, 1/8, 1/16, 1/32)

EXIT Press to back to the previous menu.

ADD/ERASE (Optional function currently unavailable)

C.C. Press to call up the Close Caption (CC) and Caption Service (CS) list. You can pre-select one to see Closed Caption.

P.CTRL Press to access Parental Control password and/ or program parental locks.

COLOR BUTTONS (Optional function currently unavailable)

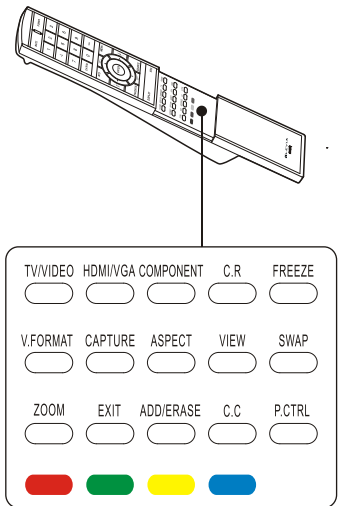

Hot Keys - Navigation and Description

Each hotkey was designed to allow you to directly access certain functions available through the OSD menu. Instead of navigating through the OSD menu, hotkeys is the shortcut to viewing or making display changes at the touch of a key.

Below, each screen is displayed with the following information, for each hotkey pressed. Note that you can always access the same hotkey functions in the OSD menu.

Note: Some hotkey function may not currently be available. Please refer to the model specifications for available TV functions in your area or country.

MTS

This hotkey switches between SAP, Mono or Stereo Mode. Press MTS hotkey to switch sound effect mode each time. Modes can be selected depending on the program broadcast signal your TV receives. This function can be accessed through the Audio setting in the OSD Menu.



Freeze

This hotkey freezes the picture within the frame of your TV, while the volume continues at normal time. To unfreeze, press the Freeze button again.



Display

This hotkey displays the information for current channel, number, and time.

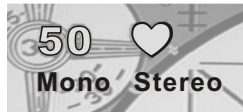

Source

This hotkey displays the source you are currently viewing.



TV

This hotkey directly selects the current video signal from an A/V or Antenna Source. The screen will display the TV source on the upper right hand corner of the screen.

DVI/VGA

This hotkey directly selects the current video signal from an HDMI or VGA Source. The screen will display the HDMI or VGA on the upper right hand corner of the screen.

VIDEO

This hotkey directly selects the current video signal from a Video Source. The screen will display the Video source on the upper right hand corner of the screen.

COMPONENT

This hotkey directly selects the current video signal from a Component (YPbPr, YCbCr) Source. The screen will display the Component source on the upper right hand corner of the screen.

C.R.

This hotkey function is currently unavailable.

V.FORMAT

This hotkey enables you to change TV picture resolution between 1920 x 1080i; 1280 x 720p; 720 x 480p; 720 x 480i video format through YpbPr, RGB or DVI connectors.

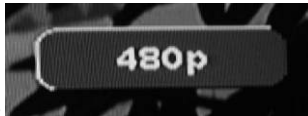
**ASPECT**

This hotkey enables you to change the aspect ratio between the picture and screen. Aspect ratio includes Full, 4:3, 16:9, and Panoramic viewing ratios.

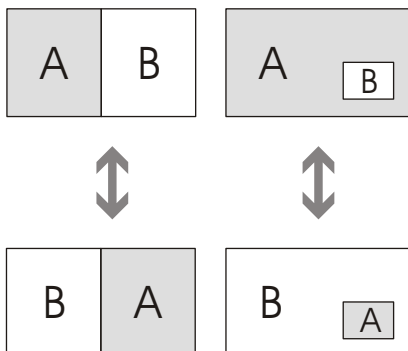
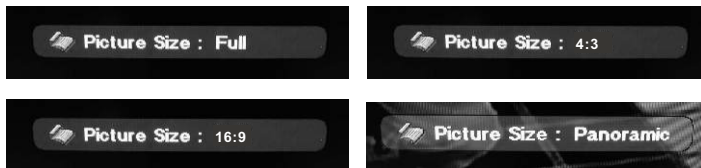
**VIEW**

This hotkey enables you to choose viewing options between PIP (Picture In Screen), Split Screen and OFF.

SWAP

This hotkey enables you to swap channels between each screen view in PIP or Split Screen mode. Press the hotkey to switch between channels.

FAVORITE

This hotkey enables you to directly view your favorite channels as pre-programmed in the OSD Menu Favorites section. Press the hotkey each time to flip to your favorite channel.

**EPG**

This hotkey is available only in the DTV source. By pressing this key, it enables you to quickly view a summary of shows and times at the channel you are currently on. You may navigate through the menu using the <- and -> keys, and pressing "Enter" to choose the channel you wish to view. Press "Exit" to leave this menu.

**EXIT**

This hotkey will let you exit from any hokey or OSD view, to your normal TV view.

SLEEP

This hotkey will start the sleep timer option, which includes a 60 minute, 90 minute and 120 minute option for an automatic TV shut-off.

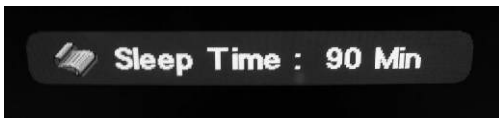
**C.C**

This hotkey will turn on the closed captioning option at the bottom of your screen. You may directly choose between the following: C1, C2, C3, C4, T1, T2, T3, T4, Off

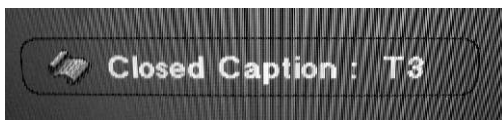
**P.CTRL**

This hotkey will directly take you to the Parental Control settings page. You must first enter the password to access this option. If you haven't set a password, you will need to do so first through the OSD Miscellaneous Section for Parental Control.



Battery Installation

1. Push the tab and pull it out as illustrated below.
2. Insert two size AAA batteries (supplied) by matching the (+) and (-) on the batteries to the diagram inside the remote control's battery department.
3. Replace the cover back and make sure the cover "snaps" into the remote control.

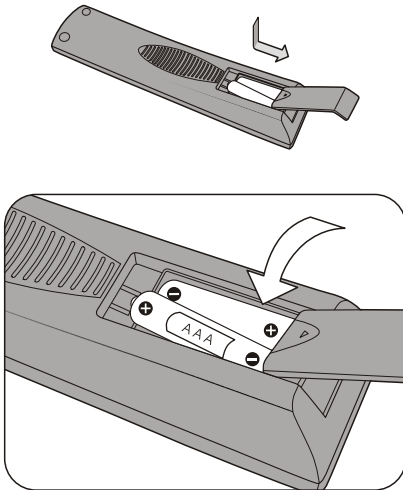

Note:

1. The display unit comes with two new AAA batteries as accessories. However, due to uncontrollable causes, the electricity of the accessorized batteries may be partially or completely drained. We do not warrant the quality of the batteries in any case since many factors are considered. If replacement is needed, please purchase two AAA batteries.
2. Handle remote with care. Avoid dropping it, placing in direct sunlight, near a heater, high areas of humidity or getting it wet. If the remote gets wet, please wipe it dry immediately. In the event of the remote not working properly or is inoperational, a replacement of remote control may be required.
3. If you do not use the remote control for a long period of time, please remove the batteries and store in a cool place to preserve battery life.
4. Do not mix new and used or with different types of batteries for operation.

Adjusting On Screen Displays (OSD)

Introduction

After you have finished connecting your TV, you are now ready to choose and personalize your TV settings in the OSD (On Screen Display) menu.

There are four main sections in the OSD Menu:



To Operate in the OSD

1. Press "Menu" button to enter OSD menu mode.

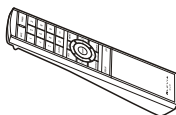

2. To select between main functions, use the keys "VOL - " and " VOL+ "

3. To select the function, press the keys "CH+ " and "CH- "

4. To adjust the value bar, used the keys "VOL - " and " VOL+ "

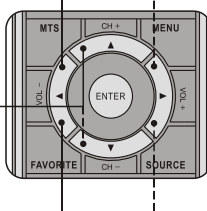

5. After choosing your setting, press "Menu" to exit and back to last picture.



6. To exit the OSD menu, press "Menu" again and again until exit the OSD menu, or without action for 12 seconds of inactivity. This is also adjustable in the OSD.



VIDEO Adjusting TV Picture Settings

Advance Video Quality

In this Setup Index, you can adjust the video and picture settings to suit your personal preferences.



Video Settings

Item	Adjustment	Function
Brightness	0~100	Adjusts picture brightness contrast
Contrast	0~100	Adjusts picture color contrast
Saturation	0~100	Adjusts the color intensity
Hue	0~100	Adjusts the tint or shade of picture
Sharpness	0~100	Adjusts the picture sharpness or softness
Color temp	Cool / Middle / Warm / User	Adjusts image color intensity. Cool: More blue-tinted colors Middle: Standard color temperature Warm: More red-tinted colors User: Allows User to adjust RGB Gain
Red Gain	0~100	Adjusts the color control with red tones
Green Gain	0~100	Adjusts the color controls with green tones
Blue Gain	0~100	Adjusts the color controls with green tones
Backlight	Bright / Middle / Dark	Adjusts the darkness or lightness of the screen
Auto Setting	Enter	Adjusts OSD Settings back to factory default
Advance Picture Adjust	Enter	Adjusts additional specific picture settings (DNR, Black Level Extender, White Peak Limitor, Flesh Tone, Adaptive Luma Control)

Advance Picture Adjust

To further adjust specific picture settings, enter this function by pressing the ► button.



Advance Picture Adjust

Definition of Terms

Item	Status	Description and Function
DNR	Off/Low/Middle/Strong	DNR-Dynamic Noise Reduction. Reduces high frequency noise dynamically. Off- Dynamic Noise Reduction is disabled. Low/Middle/Strong---Set the DNR in low/medium/strong degree.
Black Level Extender	On/Off	Black Level Extender -Extends "grays" to black so a more accurate picture is produced with a wider contrast scale. On-The Black Level Extender is enabled. Off-The Black Level Extender is disabled.
White Peak Limitator	On/Off	White Peak Limitator-Limit the signal amplitude varying degree resulted in brightness over saturation. On-The White Peak Limitator is enabled. Off-The White Peak Limitator is disabled.
Flesh Tone	On/Off	Most LCD TV's video processing solutions have a red push to the their color matrix. With the Flesh Tone Control option, it helps to tone down these strong reds and produce more naturalistic color tones. On-Flesh tone adjustment is enabled. Off-Flesh tone adjustment is disabled.
Adaptive Luma Control	On/Off	Control the luminance adaptively. On-The Adaptive Luma control feature is enabled. Off-The Adaptive Luma control feature is disabled.

To Adjust Settings:

Use the ► and ◀ remote buttons to adjust each Video picture setting, as seen below:

Brightness



Saturation

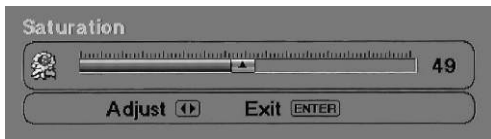

Hue

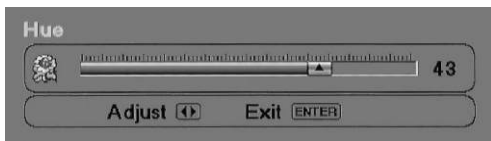

To exit, press the  Button

To Reset Factory Settings

If, at any time, you wish to go back to original factory setting, you may do so by choosing the Default setting in the OSD Picture and Audio Sections.

Selecting "Default," will reset all OSD settings to the original manufacture settings. The only items which will remain unaffected, are:

- Clock
- Auto Scan Channels
- Edited Channels
- Parental Control Password

Audio Adjusting Sound Quality



Audio setting

Definition of Terms

Item	Adjustment	Function
Treble	-50~50	Adjusts higher pitched sounds
Bass	-50~50	Adjusts lower pitched sounds
Balance	-20~20	Adjusts volume balance in Left and Right
Surround	On / Off	Creates a panoramic stereo audio image by producing deep and rich bass tones and clear treble tones. This enables you to enjoy powerful sound effects like those in a movie theatre
Equalizer 1	Off, Concert, Living Room, Hall, Arena, Church	Adjusts the sound as occurred in an enclosed space of varying spaces
Equalizer 2	Off, Rock, Pop, Live, Classic, Soft	Adjusts the volume of different bands (ranges of frequencies (HZ)) to control the overall sound
MTS	Mono, Stereo, SAP	Adjusts sound reception of stereo, bilingual and mono programs under the TV Source.
Speakers	On / Off	Turns off the speakers of the TV when using a Receiver or Home Theater System.

To Adjust Settings:

Use the ► and ◀ remote buttons to adjust each Audio sound quality, as seen below:

Treble

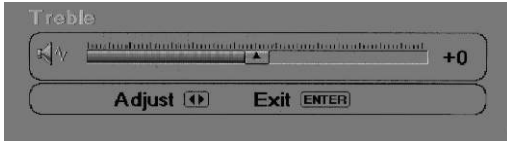

Bass

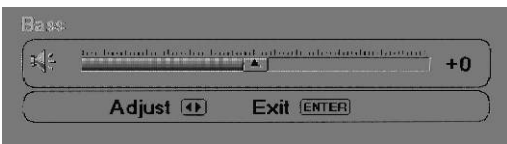

Balance

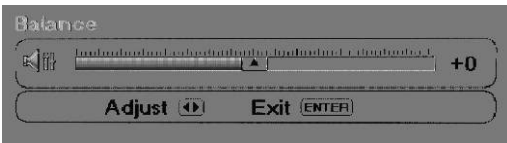

Surround Sound is an available option for creating a panoramic stereo audio image by producing deep and rich bass tones and clear treble tones. This enables you to enjoy powerful sound effects like those in a movie theater.

Speakers

Must turn off speakers of the TV when using a Receiver or Home Theater System.

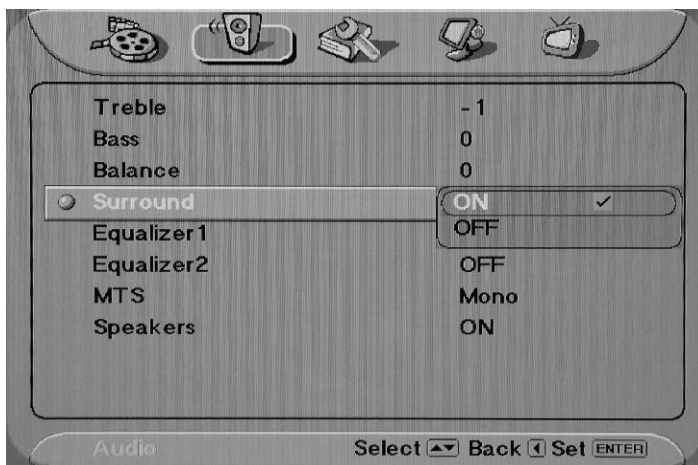

OSD Audio Settings: Equalizer 1



OSD Audio Settings: Equalizer 2



MTS System for Stereo TV

You can enjoy stereo, bilingual and mono programs.



Additionally, you can press the hotkey "MTS" until the desired sound indication appears. Each time you press the button, the sound indication changes as follows:

Mono, Sap, Stereo

Definition of Terms

Sound Effect	Description
Stereo	Select for stereo reception when viewing a program broadcast in stereo
SAP	Select to automatically switch the TV to Secondary Analog Program when a signal is received. (If no SAP signal is present, the TV remains in Stereo Mode)
Mono	Select for mono reception. (Use to reduce noise during weak stereo broadcasts)

MISCELLANEOUS Adjusting Personal TV Settings

In this Section, you can adjust additional TV settings to your personal preference, including channel setup, choosing tuner modes, setting up timer, closed caption services, parental controls, and viewing the OSD in your preferred language.



Description of Settings

Item	Adjustment	Function
Channel Setup		Setting up Channel functions
Channel-Favorite	24 favorite channels setting	Stores the favorite channels
Channel-Skip		Sets up available channels. Add : To add available channel. Skip : To cancel available channel
Channel-Name		Stores channel names
Tuner Mode	Air / Cable	
Auto Search		Selects to auto scan the available channels of the TV or CATV.
Timer	Time, Start/Stop Time, Channel, Activate option, Display option	Set Alarm with channel preference
Closed Caption	C1, C2, C3, C4, T1, T2, T3, T4	Switches different types of caption or cancel caption functions.
Parental	MPAA G/PG/PG-13/R/NC-17/X Tv rating TV-Y/TV-Y7/TV-Y7-FV NPAA Unrated TV-G/TV-PG(V,S,L,D)/ TV-14(V,S,L,D)/TV-MA(V,S,L) TV None Rating Password	Adjusts MPAA and TV Ratings under parental control settings and setup password lock.
Language	English / Deutsch / Francese / Italiano / Español / Português and Пycckий. 繁體中文 / 簡中	Switches the OSD language
Default		Resets OSD setting to default.

Setting the Channels

After you finish connecting your TV, you can run Auto Scan program to setup your channels. The program will scan and preset all receivable channels automatically.

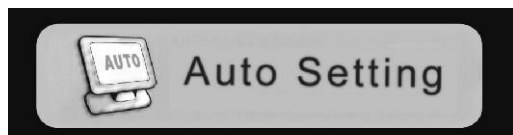

To Cancel Auto Program

Exit auto scan program by pressing "menu" Key.

Note: The Auto Scan is set to scan cable TV channels by default. You cannot receive and set the cable TV channels VHF/ UHF channels at the same time.

Setting Favorites Channels

You can select and store a list of your favorite channel settings. Selected favorite channels are marked with a  icon.



You can preset favorite channels on this page. You can also access this function by pressing the " FAVORITE " hotkey on the remote control and select or switch between your favorite channels .

1. Enter "Channel-Favorite" mode.
2. Press "Edit " to enter the channel(s) using the number keys.
You can "Delete" channels per line or "Empty" all channels at once.
3. Press "View" to see the selected channel display in real time.
4. Press "Enter" to exit when complete.

Watching favorite channels

To watch your favorite channels after specifying your preferences, just press the Hotkey "FAVORITE" to browse through each favorite channel.

Editing Channels

You can also edit channels to your personal preference. Once you edit a channel, it will be skipped when surfing through TV channels.

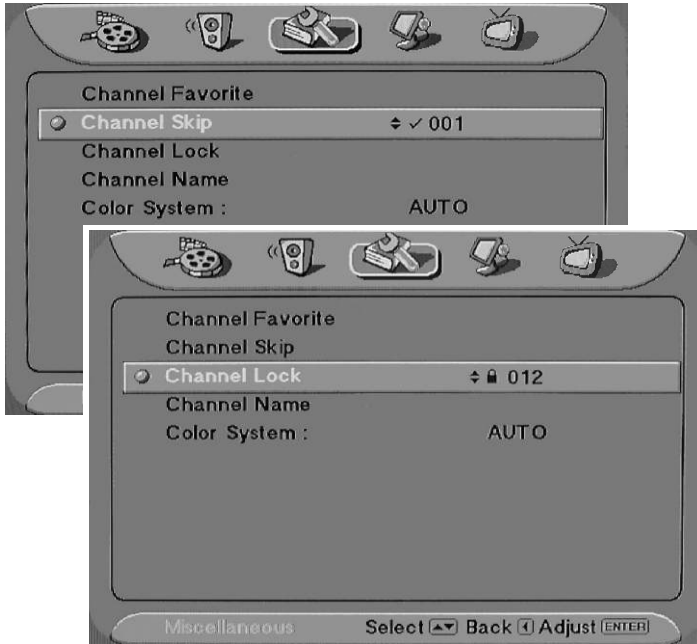

To Skip or Lock a Channel

1. Make sure Channel Skip or Channel Lock is highlighted.
2. Enter the channel number you wish to skip or lock, or scroll through channels using the ▲ and ▼ Arrow.
3. Press "Enter" to make your selection or adjustment.
Note: You will see a checkmark next to Skipped Channels, and a small lock icon next to Locked Channels.
4. Press ◀ to exit when complete.

To Undo a Skipped or Locked Channel:

1. Make sure Channel Skip or Channel Lock is highlighted.
2. Enter channel number you wish you undo, or scroll through channels using the ▲ and ▼ Arrow.
3. Press "Enter" to make your selection or adjustment.
Note: You will NOT see a checkmark next to Skipped Channels, or a small lock icon next to Locked Channels afterwards.
4. Press ◀ to exit when complete.

Personal Channel Preferences: Channel Naming

You can also create personal names for each channel, which will show up in the upper Right hand corner of the TV screen.

To Name a Channel:

1. Enter Channel Name sub-page
2. Enter Channel name using alphabet-numerical keypad as seen below:



3. Press "Okay" to exit keypad when naming is complete.

Once you have named a channel, your preset channel name will show up on the TV screen when flipping through channels, or by pressing the Display Key.



If you named your favorite channel, you will see the heart icon  next to the channel name.

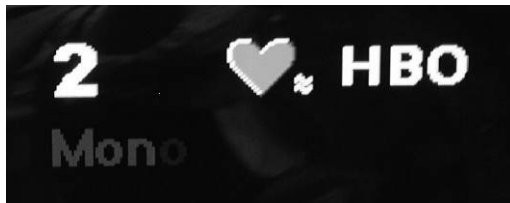

Setting up the TV Timer



To setup the time on the TV:

1. Using ▲ and ▼ keys, enter in HH: MM: SS Enter the time using the number keys found on the remote.
2. press "Enter" when complete.

NOTE: Clock will NOT BE affected when Factory Default settings are reset. Under Activate, "ON" allows the start/stop time to be ongoing whereas, "ONCE" allows it to only function once.

However, when the power cord is not connected to the TV, you will lose all previous time adjustments.

Timer: Start Time / Stop Time

You can set the TV to turn On and/or Off automatically at a predetermined time through the timer function. Use the Start Time to setup the hour and minute preferences. Your TV will automatically turn on at the set time. Use the Stop Time to setup the hour and minute preferences. Your TV will automatically turn off at the set time.

Note: Alarm WILL BE affected when Factory Default settings are reset.

When the power cord is not connected to the TV, you will lose all previous saved adjustments.

Watching with Closed Caption



You can display closed captioning if the broadcaster offers this service.

Close Caption option can be set On/Off from the OSD page. This function also can be accessed by pressing "C.C" hotkey on the remote control.

1. Not all programs offer the Closed Caption option.
2. Closed Caption may not be seen clearly (white blocks, strange characters, etc.) if the signal condition is poor, or if there are technical difficulties with the broadcaster.
3. If no TEXT broadcast is being received while viewing in the [TEXT] mode, the screen may become dark and blank for some programs. Switch Off the Closed Caption mode.

TV OSD Languages

There are nine language formats available for the OSD Menu. You may choose from the following:

English, Chinese Traditional, Chinese Simplified, Deutsch, Francese, Italiano, Español, Português and Русский.



Using the Parental Control Feature

To block programs you feel unsuitable for your children, you need to Set the TV for desired rating systems. The TV Parental Control feature functions by receiving the rating signal from your local broadcasting station or cable service provider.

The TV programs and movies shown on TV are given a rating signal based on the following rating systems.

In U.S.A.: U.S. Television Parental Guidelines to rate television programs (U.S. TV Ratings) and Motion Picture Association of America (MPAA) Guidelines to rate movies including those shown on TV (Movie ratings).

In Canada: Canadian English Language ratings to rate television programs in English, and Canadian French Language ratings to rate those in French.

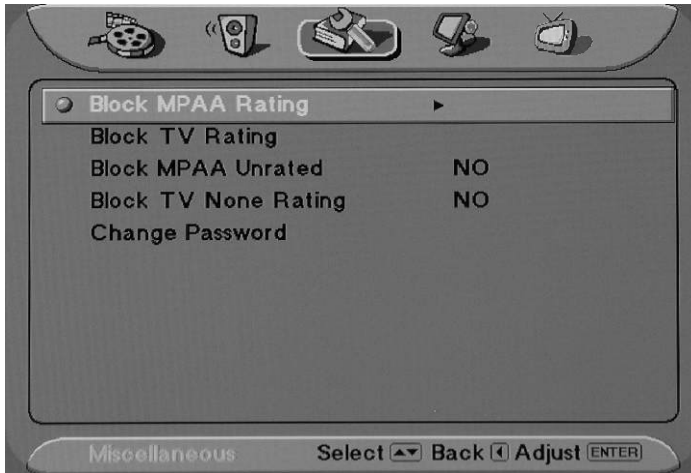

Parental Control

1. This function allows programs to be restricted and controlled by parents based on FCC regulation. It prevents children from watching program contents that may be prohibited by parents.
2. Restriction of programs is based on three Rating Systems: MPAA Rating, TV (Child) Rating and TV (Entire Audience) Rating. The MPAA Rating restricts based on age. TV (Child) rating and TV (Entire Audience) Rating restrict based on age and contents.
3. When you block the lower rating, the higher age-based ratings are blocked automatically.
4. When you enter "Parental control" mode, those messages display for different state.

The Parental Control Main Menu contains four options in the following categories:

- 1.MPAA Rating
- 2.TV Rating
- 3.MPAA Unrated
- 4.TV Unrating

Activating the Parental Control Feature

Once you enter the highlighted section of Parental Control, you will have to enter your password. The Factory Default password is "9999". Once you enter the Parental Control Menu, you may change the password to your personal preference.



To setup, enter each sub-menu to setup your parental controlled TV channels.

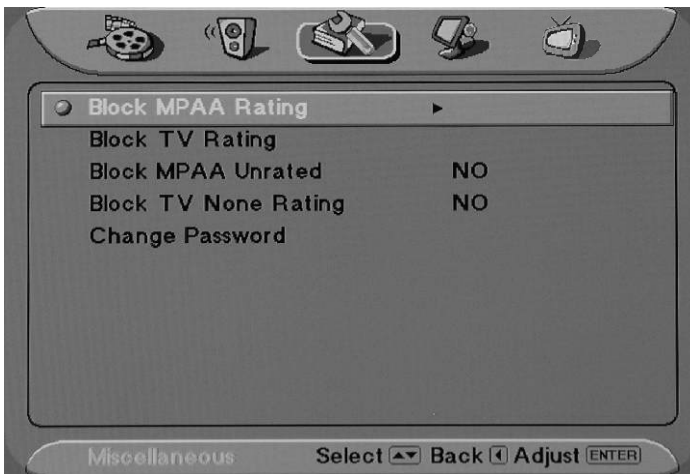

MPAA Rating controls channels and movies that are rated from **G**, **PG-13**, **R**, **NC-17**, and **X**.

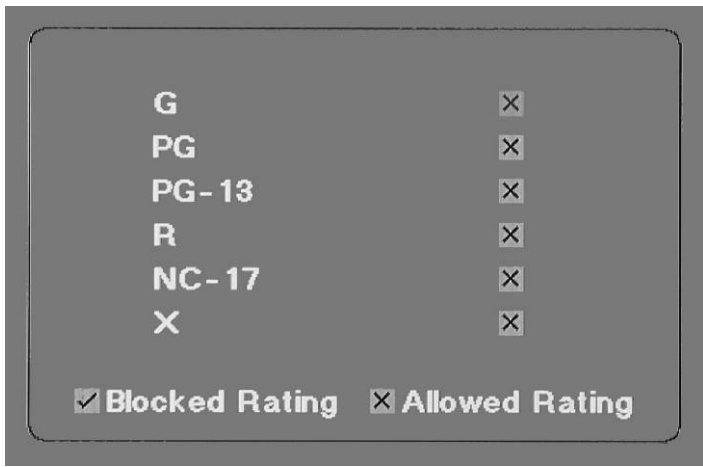

TV Rating controls channels and movies that have been rated from **TV-Y**, **TV Y-7**, **TV-G**, **TV-PG**, **TV-14**, and **TV-MA**.



To Block Unrated Channels

You may choose "YES" for Block MPAA Unrated and Block TV None Rating. This will lock you from accessing any channels that do not contain MPAA or TV Ratings. To watch unrated channels, re-activate Block MPAA Unrated and Block TV None Rating to "NO".

Setting up Parental Control Password

Enter the password sub-page. Enter the current password. If this is the first time, you do not have to enter a password.



You will have to enter and confirm your password before changing to a new password. Please keep password within 4 numbers.



If you enter the incorrect password, you will see an error page. Please re-enter the new password and confirmation password again.

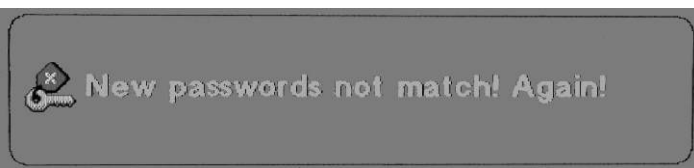

Note: If you forget the password, press "9999" to lift the Password lock and change to a new preferred password.

Factory Default Option



Reset Factory Settings:

Initiating Factory Default will reset all OSD settings to original manufacture settings. The only items, which will remain unaffected are:

- Clock
- Auto Scan Channels
- Edited Channels
- Parental Control Password

Adjusting Screen Modes

There are two options in the Screen Modes, "Aspect" & "View." Aspect will allow user to select different aspect ratios, whereas, View will allow different modes of viewing 1 or 2 sources.



Changing the Screen Mode



You can alter the aspect ratio of a picture by choosing between these four options:

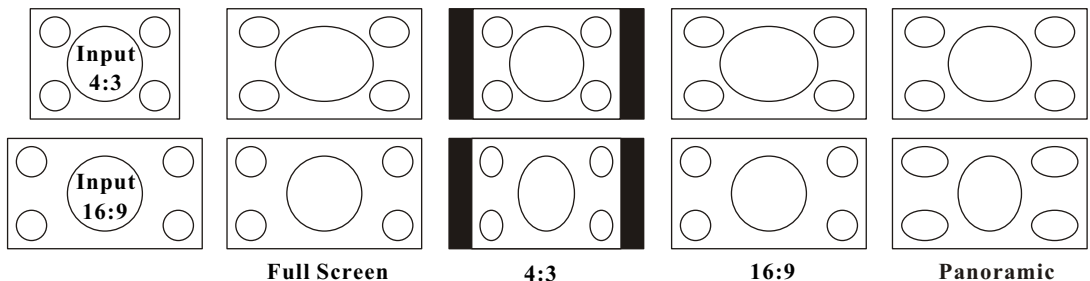

Full Screen Enlarges the picture to 16:9 wide mode, by stretching the picture horizontally only.

4:3 Returns the 4:3 picture to its original size. This is considered the "normal" viewing mode.

16:9 Enlarges (zoom-in) the size of a 4:3 picture on screen as geometric ratio, keeping the original image as much as possible.

Panoramic select to widen the displayed image. (only applies to content larger than 16:9)

Changing the View Modes

You can select four view types of picture modes that best suits the program you are watching. You can set a different view mode for each video mode for each input and store it manually.



View Modes	Function
PIP	Picture-in-Picture has a Main screen and small screen view
Split Screen	Full Screen split in two Views

Picture in Picture (PIP)

Allows you to view a main screen (Picture 1) and a secondary small screen (Picture 2).

Press 'source' button to switch from P1 to P2 and vice versa.

You may also choose the settings of P1 and P2 as well as the position of P2 on screen.

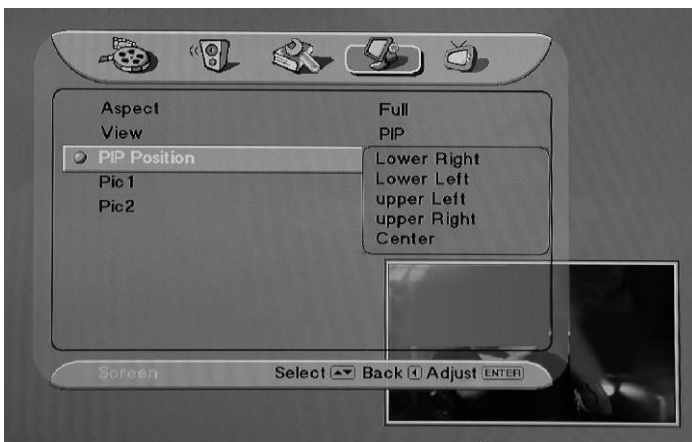

OSD View



TV View

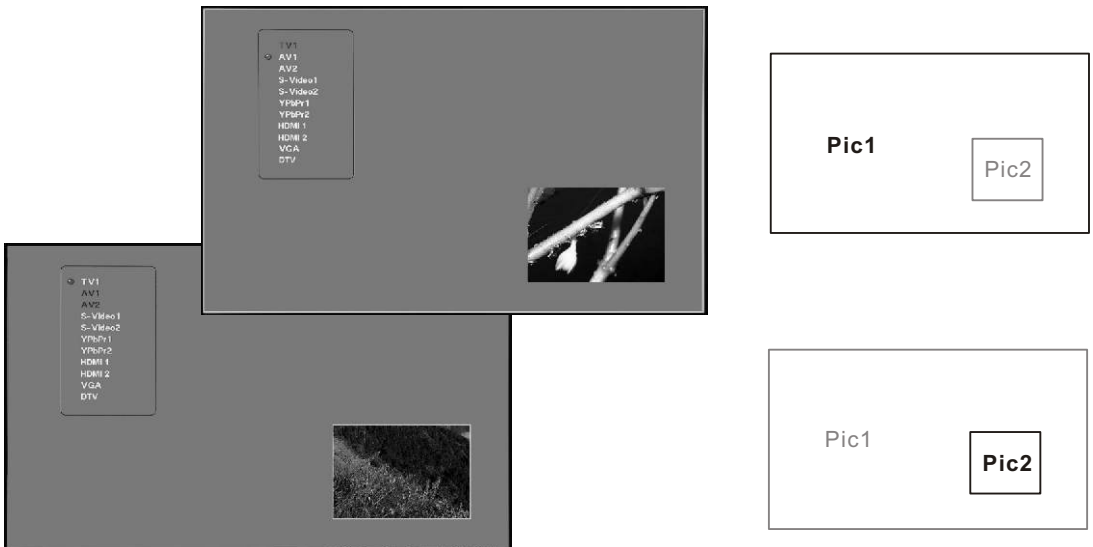

PIP mode

You may adjust setting for each Picture source. Pic 1 allows for a TV, AV1, AV2 and DVI sources while Pic 2 supports all other input sources.

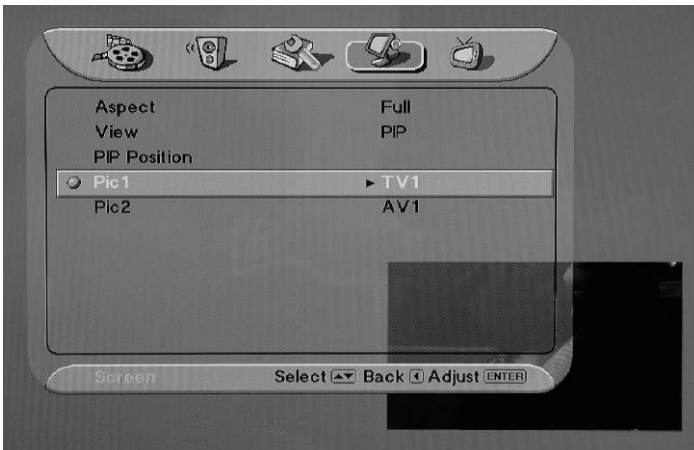

Item	Adjustment	Function
PIP Position	Upper Left / Upper Right / Lower Left / Lower Right	Changes the position of Picture 2
PIP-Pic1	TV1, AV1, AV2, HDMI 1, HDMI 2	Switches the source of Picture 1
PIP-Pic2	AV1, AV2, S-Video1, S-Video2, YpbPr1, YpbPr2, HDMI 1, HDMI 2, VGA, DTV	Switches the source of Picture 2

Note: Pic 1 allows for a TV, AV1, AV2 and. Pic 2 allows for all sources except TV or if you are already using one of the other sources from Pic 1.

When you use the swap function, the signals from the main window and the PIP window will swap positions no matter what sources you specified on either window.

Split Screen

Allows you to view two separate screens simultaneously (Picture 1 and Picture 2).

Press 'source' button to switch from P1 to P2 and vice versa.

OSD View



TV View

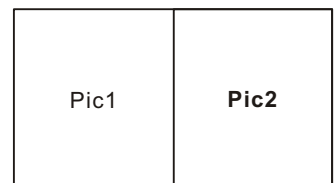
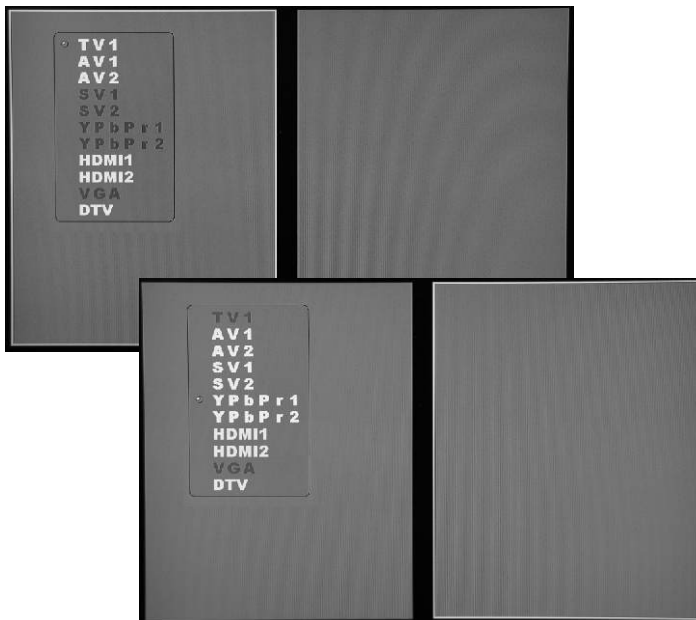

Split Screen mode

You may adjust setting for each Picture source. Only Pic1 supports a TV input source, while Pic2 supports all other TV input sources.

Item	Adjustment	Function
Pic1	TV1, AV1, AV2, HDMI 1 HDMI 2	Switches the source of Picture 1
Pic2	AV1, AV2, S-Video1, S-Video2, YpbPr1, YpbPr2, HDMI 1, HDMI 2, VGA , DTV	Switches the source of Picture 2

Note: Pic 1 allows for a TV, AV1, Av2 HDMI 1 and HDMI 2. Pic 2 allows for all sources except TV or if you are already using one of the other sources from Pic 1.

When you use the swap function, the signals from the main window and the PIP window will swap positions no matter what sources you specified on either window.

DTV: Adjusting DTV Settings



Introduction to DTV

A Brief Look at Broadcast and Digital Television

Broadcast television is a traditional way of watching TV programs simply by installing an antenna. This is called analog TV. In recent years, many countries have begun to mandate a transition from analog to digital television. Digital TV provides noise-free, high-definition picture quality, Dolby AC-3 sound effects, and a handy EPG (electronic program guide). And the 16:9 video format gives a wider view than the traditional 4:3 format. Many TV broadcasters are now delivering digital TV programs, so switching to a digital HDTV receiver now makes good sense.

Digital TV programs are broadcast on both VHF and UHF frequency bands. Traditional analog TV uses one frequency channel to carry a single station's program. With digital TV, one frequency channel can carry up to four station programs. For example, analog channel CBS 2 may have become 2-1, 2-2, etc. when broadcast in digital TV. Channel 2 is the major channel and channel -1, -2, etc. are the sub-channels.

Digital TV signals are transmitted in either free-to-air (FTA) or pay-per-view (PPV) mode. FTA programs are received free with an MPEG 2-ATSC compliant digital receiver, such as the HDTV-ST. PPV programs can be received only by paying an access fee to the broadcaster and by using a digital receiver incorporating a compatible conditional access system. In addition, the HDTV-ST lets you watch HDTV, EDTV, and SDTV digital TV programs.

- ***HDTV** stands for High Definition Television; the common video formats are "1920 x 1080 interlaced" and "1280 x 720 progressive".
- ***EDTV** stands for Enhanced Definition Television; the common video format is "720 x 480 progressive".
- ***SDTV** stands for Standard Definition Television; the common video format is "720 x 480 interlaced".

DTV Functions

The HDTV-ST Digital HDTV Receiver can receive channels from both VHF band and UHF band TV signals. All the major free-to-air station numbers currently available in your area are listed in the on-screen menu. To watch the channel, simply select the channel number.

The receiver is fully ATSC / MPEG-2 (digital video broadcast) compliant, delivering High Definition crystal-clear video and Dolby AC-3 sound. It supports a radio signal range from 50-860 MHz, so all the channels within the VHF and UHF bands can be easily programmed. It can receive major and sub-channels containing both video and audio programs.

The receiver can receive hundreds of channels simply by selecting alternate TV channel frequencies in your area. To find out the specific digital TV services available to you, please contact your local service provider or log onto the website "<http://www.antennaweb.org>" With the wide range of features and HDTV programs open up to you by the HDTV-ST receiver, you'll be ready for a new era in home theater entertainment.

Summary Of Features

The receiver supports digital functions that are fully ATSC / MPEG-2 compliant and can store up to 2,500 digital channels. It can also receive Free-to-Air digital TV programs transmitted from all the available VHF and UHF Band signals in your area. Follow the on-screen display (OSD) to guide you through the steps necessary to configure your receiver. Then begin enjoying all the video and audio channels with crisp picture quality and the crystal clear sound.

The key features of the HDTV-ST Receiver are described below.

Remote Control The remote control provides access to the full range of system features. In addition to providing access to TV programs with channel and volume controls, it can be used to operate all the system menus. You must use the remote control to configure the channel settings, select the channels you want to include in the program list and access many other configuration options.

System Menus All the receiver's features can be accessed through the system menus by simply pointing and clicking. You can navigate through all the options in the menu and press "Select" button on the remote control or "Enter" button on the front panel.

The menu includes items such as Channel Configuration, Channel List, Electronic Program Guide, Audio Options, and Parental Lock.

Parental Locks Access to certain channels with content that might not be suitable for younger viewers can be controlled by password. Program ratings are shown on the I-Plate, which can be activated by pressing "Info" key on the remote control. By pressing "Info" twice, you can access the extended program information for the current channel.

Setting Up the DTV RECEIVER

From your DTV OSD Menu, you can personalize your TV options in the following settings:

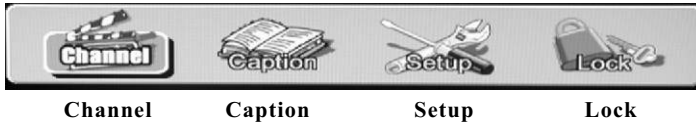

Channel

Before you can use any of the channel buttons (CH ▲ ▼, FAV.), the available channels must first be scanned and memorized.

Initial Screen

- The first time the receiver is powered on, you will see the message "**Press (Menu) key and then select Channel to run Auto/Manual Scan**". Press the MENU button to display the MENU banner.
- Use the arrow keys ◀ or ▶ to move the highlight through the menus and view the menu items.
- Press the "EXIT" button to return to the previous menu or press the "MENU" button to exit the menu system.

Auto Scan

To automatically scan your channels, follow these steps:

1. **Edit**
 2. **Auto Scan**
 3. **Manual Scan**
- Press ▲ or ▼ buttons to highlight AUTO SCAN, and then press Enter. An AUTO-SCAN window will display the SCAN status.



- The receiver scans Off-Air channels searching for both NTSC analog and ATSC digital signals from channel 2 to channel 69. The percentage bar shows the progress being made.
- Once the digital TV signal is scanned, the channel number and the program name are shown on the "Scan List".
- It takes about three minutes to complete the entire scanning process.
- Scanning ends on channel 69. When it is complete, you can press "EXIT" to leave this window or press "MENU" to exit the menu system.

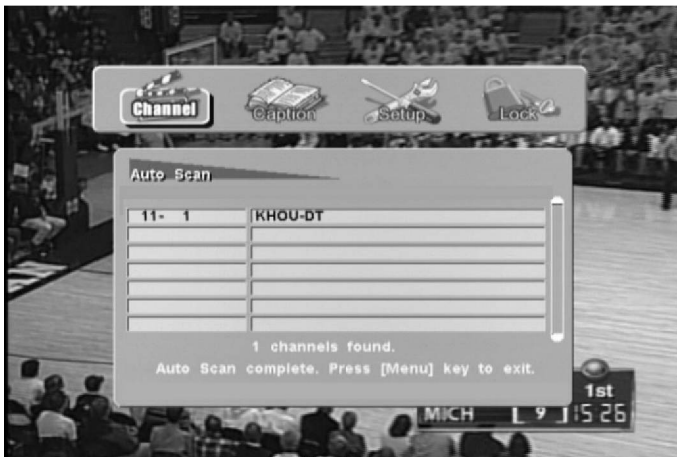

Adding Channels Manually

You can add channels manually if they aren't detected by the Auto Scan utility using the following steps:



- On the Channel menu page, select "Manual Scan", and then use the ◀ or ▶ button to select the channel connection: Air, Cable STD, Cable IRC, or Cable HRC.
- Press Enter to highlight the input column, then press numeric buttons to input the channel number. The channel frequency is automatically shown on right side of the input column.

- Press the Enter button when the messages "Add channel" and "press Enter to add channel" are shown.

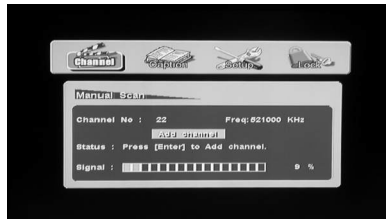

- If the ATSC signal is found and locked, you will see the Status message "Get No.XX 8VSB channel success". Press EXIT or Menu to leave the menu and watch the program, or to scan other channels.



- If the signal is not locked, you will see a "no channel" message. You can scan the signal again or refer to the signal level bar "Signal" for aligning the direction of the antenna to improve the signal.
- When the signal is locked and the receiver is on the channel, you can check the signal level.

Note: Contact the antenna installer if you have trouble locking the signal.

- Press the EXIT button to return to the main menu or press the MENU button to exit the menu system.

Edit Channels (Block or Add to Favorites List)

You can block access to channels or add them to your favorites list using the following steps:

- On the "Channel" menu, press the numeric key to input the default password "0000" or your password. Press ▲ and ▼ to highlight Edit, and then press Enter.
- To block channels, press ◀ ▶ and ▲ ▼ buttons to highlight the channel BLOCK column and press ENTER. To add channels to the favorite channel list, press ◀ ▶ and ▲ ▼ buttons to highlight the FAV column and press ENTER.



- Press the EXIT button. A confirmation window will pop up:
 - 1.Highlight "NO" and press ENTER to cancel the changes.
 - 2.Highlight "YES" and press ENTER to save the settings.



NOTE: When a blocked channel is selected, the program cannot be shown, and you will get the message "Channel is blocked" on the TV screen.



Closed Caption Options

Follow these steps to turn on closed captioning:

- Press ◀ ▶ buttons to highlight the "Caption" icon and press ENTER.

Font Size:

- Press ◀ ▶ and ▲ ▼ buttons and the ENTER button to select the desired Closed Caption font size.

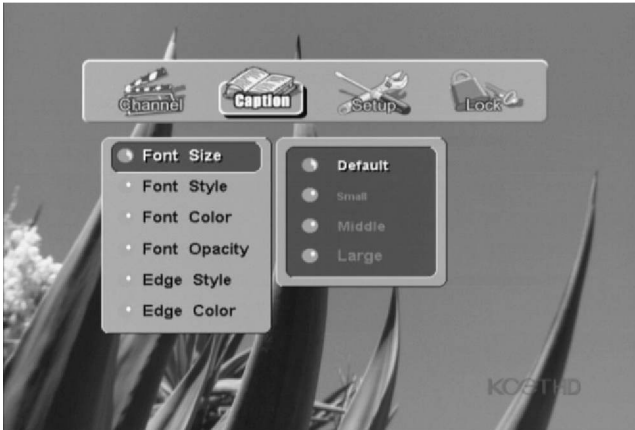

Font Style:

- Press ◀ ▶ and ▲ ▼ buttons and the ENTER button to select the desired Closed Caption font style.



Closed Caption Background Color:

- Press ◀ ▶ and ▲ ▼ buttons and the ENTER button to select the desired Closed Caption background color.

Closed Caption Foreground Color:

- Press ◀ ▶ and ▲ ▼ buttons and the ENTER button to select the desired Closed Caption foreground color.

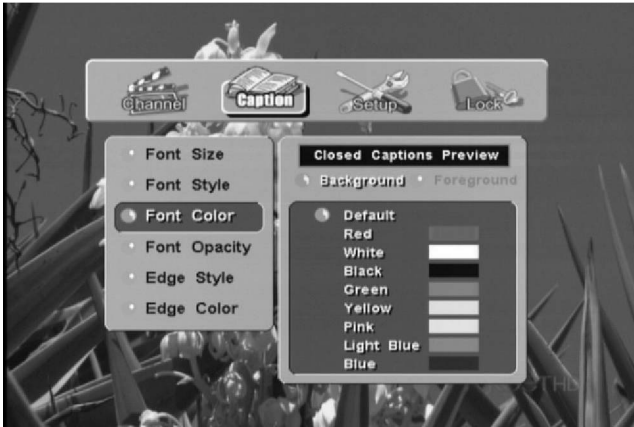
**Closed Caption Background Opacity:**

- Press ◀ ▶ and ▲ ▼ buttons and the ENTER button to select the desired Closed Caption background opacity.

Closed Caption Foreground Opacity:

- Press ◀ ▶ and ▲ ▼ buttons and the ENTER button to select the desired Closed Caption foreground opacity.

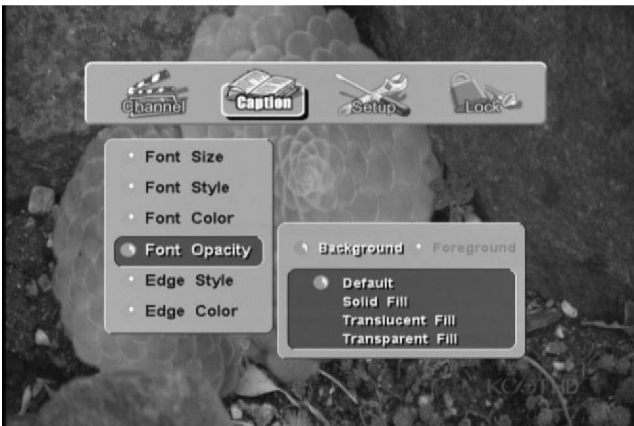

Closed Caption Edge Style:

- Press ◀ ▶ and ▲ ▼ buttons and the ENTER button to select the desired Closed Caption edge style.

**Closed Caption Edge Color:**

- Press ◀ ▶ and ▲ ▼ buttons and the ENTER button to select the desired Closed Caption edge color.

Press EXIT button to return to the main menu or press MENU button to exit the menu system.

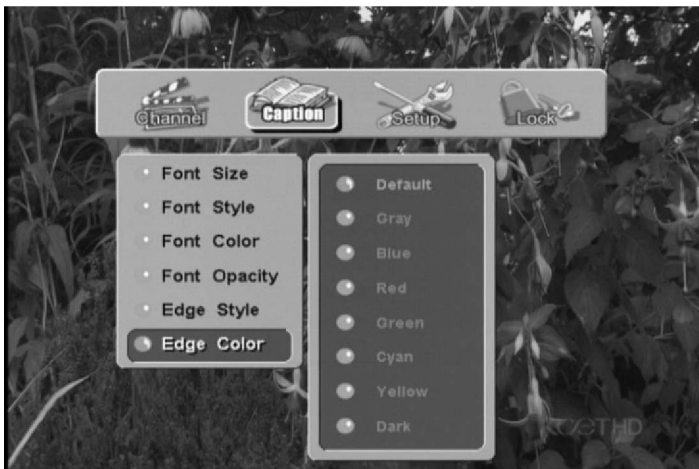

Setup

Press MENU, then use the ◀ ▶ buttons to highlight the "Setup" menu to access these sub-menus:

- 1.Format
- 2.Opacity
- 3.I-Plate
- 4.Time Zone
- 5.Language
- 6.About

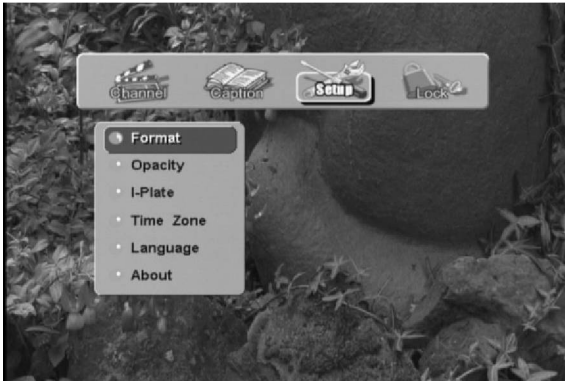

Format (Screen Format Setup)

- On the "Setup" menu, press ▲ ▼ buttons to highlight the "Format" and press ENTER.
- Press ▲ ▼ and ◀ ▶ buttons to select your screen type, video resolution and aspect ratio.
- Press the EXIT button to return to the main menu page or press the MENU button to exit the menu system.

Note: You can also change the resolution or TV Format by pressing the "V. Format" and the "A. RATIO" buttons on the remote control.

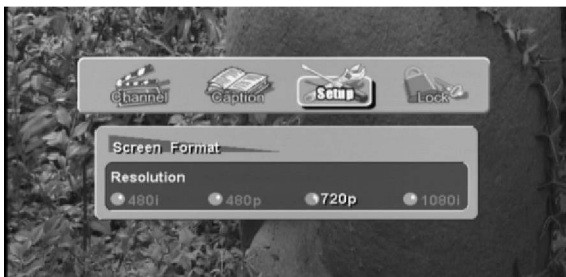

Aspect Ratio

Your options on the Screen Format menu depend on the type of TV or monitor you are using with the Receiver.

- **4:3 (Letterbox):** Select this when receiving a 16:9 source signal to see the original 16:9 format. Blank panels appear at the top and bottom of the screen.
- **4:3 (Zoom):** Select this and no blank panels will be added.
- **4:3 (Full):** Select this when receiving a 16:9 signal and you want the image to fill the entire screen.
- **16:9 (Pillar box):** Select this when receiving a 4:3 source signal and you want to see the original 4:3 format. Blank panels appear at the left and right of the screen.
- **16:9 (Zoom):** Select this and no blank panels will be added.
- **16:9 (Full):** Select this when receiving a 16:9 signal and you want the image to fill the entire screen.

4:3 TV or Monitor

If you are using 4:3 TV or monitor, you need to specify how the image is displayed.

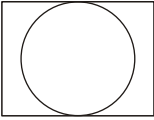
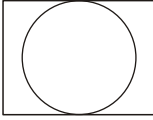
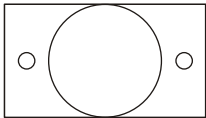
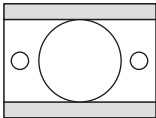
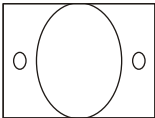
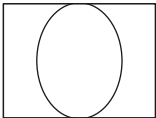
SOURCE SIGNAL	4:3 TV FORMAT		
	LETTER BOX	FULL	ZOOM
3  4			
9  16			

16:9 TV or Monitor

If you are using 16:9 aspect ratio TV or monitor, you need to specify how the image is displayed.

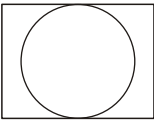
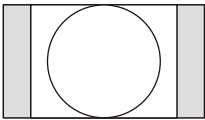
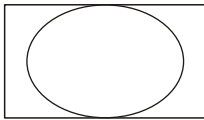
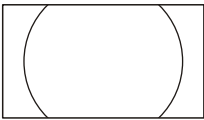
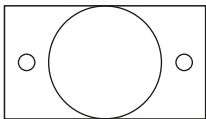
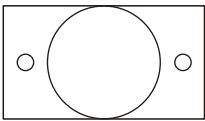
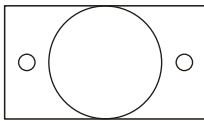
SOURCE SIGNAL	16:9 MONIOR FORMAT		
	LETTER BOX	FULL	ZOOM
3  4			
9  16			

Opacity (Transparency of On-Screen-Display)

- Press ▲▼ buttons to highlight Opacity and press Enter.
- Use the ◀ ▶ buttons to change the percentage of the On-Screen-Display's transparency.
- Press the EXIT button to return to the main menu or press the MENU button to exit the menu system.

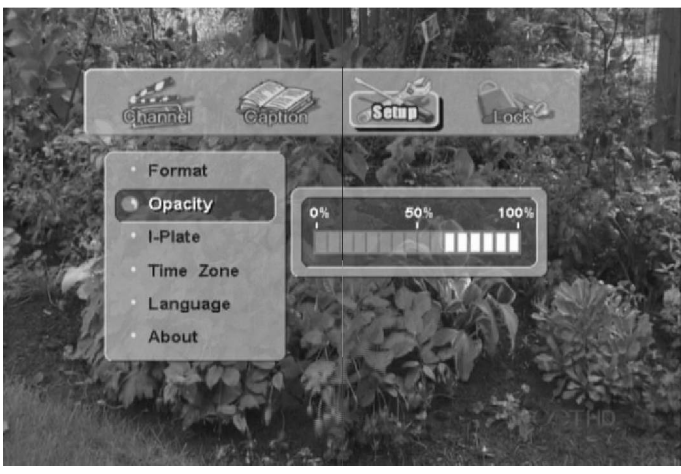

I-Plate (Display time of the information-Plate)

- Select I-Plate, then press ◀ ▶ and ▲▼ buttons to change the Information-Plate display time to 2, 4, 6 seconds or to turn it off.
- Press the EXIT button to return to the main menu or press the MENU button to exit the menu system.

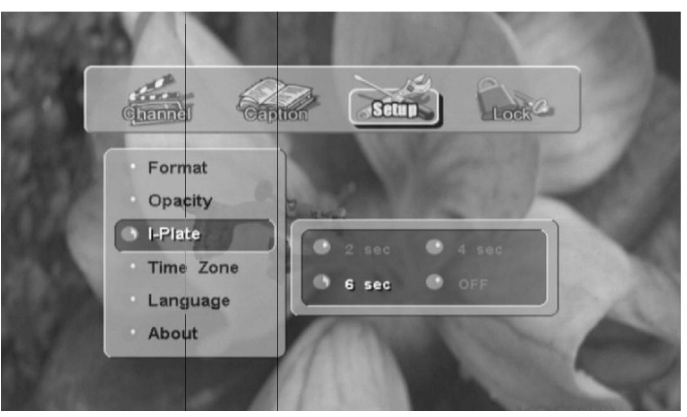

Time Zone

- Press ▲ or ▼ buttons to highlight TIME ZONE and press ENTER.
- If you are receiving a digital signal, the Receiver's time will be set automatically.
- Press the ◀ or ▶ buttons to change the time display format to 12 or 24 hours.
- Press the Enter button to highlight the input column, and then press ◀ or ▶ buttons to change the time zone 30 minutes at a time.
- Press the EXIT button to return to the main menu or press the MENU button to exit the menu system.

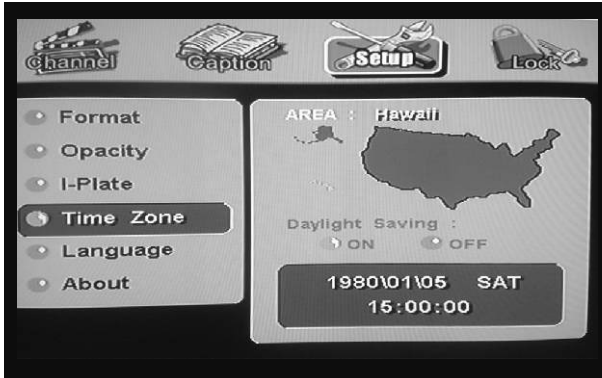

Language

- Press ◀ or ▶ buttons to highlight Language and press the ENTER button.
- Press the ◀ or ▶ buttons to change the Language display for the OSD Menu. You may choose from: English, Español, Français..



About (Receiver Information)

- Press ▲ or ▼ buttons to highlight About and press the ENTER button to see the information window containing hardware and software information.
- Press the EXIT button to return to the main menu or press the MENU button to exit the menu system.

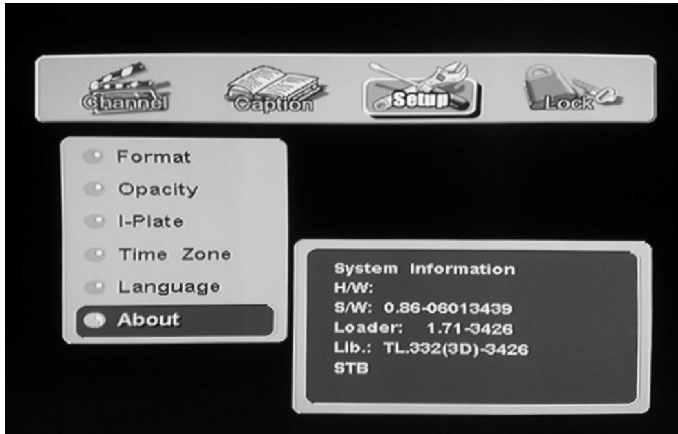

Lock Rating (Lock Programs by Rating)

- Press ◀ ▶ buttons to highlight the "Lock" icon and press ENTER.
- Enter the password correctly.



- After the password is entered, the screen will display these three sub-menus:

1. Rating
2. Password
3. Reset Box

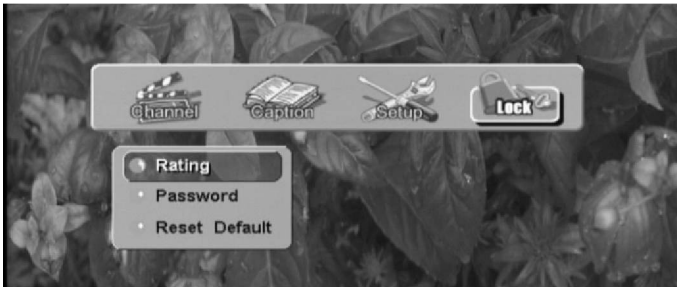

- Press ▲▼ buttons to highlight the "Rating", and then press Enter to access the rating control menu.

This menu lists both MPAA and USTV (FCC) Parental ratings. You can independently lock the MPAA and TV ratings. The locked ratings are indicated by the lock symbol.

- Press ▲▼ and ◀▶ buttons and the ENTER button to activate the appropriate restrictions for either the MPAA rating system or the USTV(FCC) rating system.
- Press the EXIT button to return to the main menu or press the MENU button to exit the menu system.



NOTE: When a locked program is accessed, you will see the message "Program is rating blocked" on the screen.

Important information About "Parental Rating"

Explanation of the MPAA and TV (FCC) Rating Systems:

USTV (FCC) Age-Based Ratings

- TV-MA** Mature audiences only. This program may contain mature themes, profane language, graphic violence and explicit sexual content.
- TV-14** Parents strongly cautioned. This program may contain sophisticated themes, sexual content, strong language and more intense violence.
- TV-PG** Parental guidance suggested. The program may contain infrequent coarse language, limited violence, some suggestive sexual dialogue and situations.
- TV-G** General audience. The program contains little or no violence, no strong language, and little or no sexual dialogue or situations.
- TV-Y7** Directed to older children. Themes and elements in this program may include mild physical or comedic violence, or may frighten children under the age of seven.
- TV-Y** All children. The themes and elements in this program are specifically designed for a very young audience, including children from ages two to six.

USTV (FCC) Content Category

V Violence.	S Sexual content.
L Offensive language.	D Dialogue and sexual innuendo.
FV Fantasy or cartoon violence.	

MPAA Rating System (Movies)

- G** General audience. No restriction.
- PG** Children under 13 should be accompanied by an adult.
- PG-13** Parental guidance suggested. Children under 13 should be accompanied by an adult.
- R** Restricted. Viewers should be 17 or older.
- NC-17** Not classified. Viewers should be 17 or older.
- X** Adults only.

* USTV (FCC) ratings: When the rating that you select is locked (as indicated by the green lock symbol), all of the content-based ratings are locked within the rating group. For example, locking the TV-G rating locks all of its contents (V, S, L, and D). More restrictive ratings (TV-PG, TV-14, and TV-MA) and all of their contents are also automatically locked.

* MPAA ratings: The particular rating that you have selected will be locked. In addition, more restrictive ratings will be locked as well.

* Neither USTV (FCC) ratings nor MPAA ratings apply to news programs.

Change Password

Access to the "Lock" or "Channel" menu is controlled by a Password. You need to enter the correct password to access these functions.

- Press the MENU button on the remote control.
- Press ◀ or ▶ buttons to highlight the **Lock** icon. Then press ▲ or ▼ buttons to highlight the Password and press ENTER.
- Follow the description on the pop-up window to press numeric buttons to input the new password and confirm it.
- Press the EXIT button to return to the main menu or press the MENU button to exit the menu system.

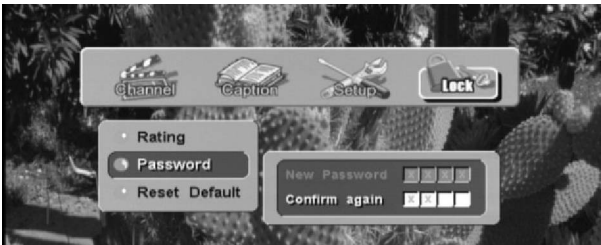

Reset Receiver's Settings to their Defaults

The "RESET Box" function lets you reset the LSTD2 Receiver settings back to the factory default status.

- In the "Lock" menu, press ▲ or ▼ buttons to highlight the Reset Box, then press Enter. When the message "Press YES will reset box to default value" appears:
 1. Highlight "YES" and press Enter to reset.
 2. Highlight "NO" and press ENTER to cancel the setting.
- Press the EXIT button to return to the main menu or press the MENU button to exit the menu system.



You must reset the Receiver back to its default status if you forget the password. You will lose all your settings after the Receiver has been reset.

- Using the "POWER" button on the front panel or remote control, cycle the power off and back on again. When the front panel LED displays "boot", press these buttons in a sequence: "▲", "▼", "◀" and "MENU-SELECT". The Receiver will be reset as the default status automatically.
- Use the default password "0000" to access the Lock menu and set a new password.
- Be sure to repeat your channel Auto Scan before using the receiver.

INFO (Information-Plate)

When you are watching digital channels, you can view the current program name and relevant information by pressing the "DISPLAY" button to show I-Plate on screen.

Current Program

- After pressing the INFO button, the I-Plate appears including this information:
 - TV Station Name
 - Current Channel Number
 - Current Local Time
 - Program Name
 - Program start and end time
 - Picture resolution
 - Closed Caption
 - Audio System (Dolby 5.1 or PCM)
 - Program Rating Information



Next Program

- Press the ▶ button to display information for the NEXT program.
Press the ◀ button to display information for the PREVIOUS program.

Extended Program Information

- Press the DISPLAY button again to display extended program information for the current TV channel.
- Press the DISPLAY button again to close the I-Plate or Extension window, or press the EXIT button to exit the I-Plate window.

Note: Be sure the receiver is tuned to a TV channel when you press "DISPLAY".



EPG (Electronic Program Guide)

- Press the EPG button to display the Program Guide window.
- The current program will be highlighted automatically in yellow.
- Press ◀ or ▶ buttons to scroll the program list to the left or right and view up to 12 hours of program guide information.
- Press ▲ or ▼ buttons and scroll through the program list upward or downward to view the program guide for different channels.



Channel Guide

- Press the Display button to see the Channel Guide. Press ▲ or ▼ buttons to scroll through the channels in the list.



CLOSED CAPTIONS

- If the I-Plate indicates that there is Closed Caption data on the current channel, pressing the CC/CS button on the remote control will display the C.C. Options list on the TV screen.
- Use ▲ and ▼ keys to highlight the desired CC signal and press the ENTER button.
- Press the EXIT or CC/CS key to close the CC Options list and view the program with Closed Captions.



FAVORITE CHANNELLIST

- When you are watching broadcast or cable TV channels, you can press the "FAV" button on the remote control to display the Favorite Channel List.
- Use ◀ and ▶ keys to select the "ALL", "ATSC", "NTSC" or "FAV" program lists.
- Use ▲ and ▼ keys to highlight the program you want and press the ENTER button.

Note: The channel table of the Receiver will follow settings in this menu. To view ATSC channels only, select the ATSC channel list. To browse all of the ATSC and NTSC channels, select the "All" channel list. If you are browsing ATSC channels and would like to switch to NTSC channels, select the NTSC channel list in this menu.

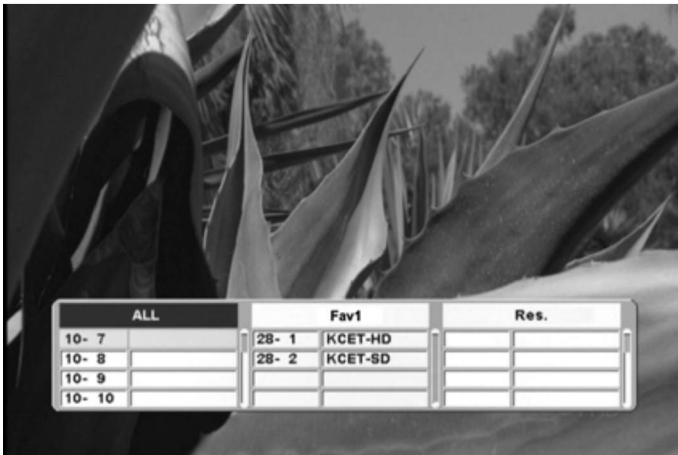

Selecting Digital Channels

Selecting digital channel numbers is different from selecting traditional channel numbers. For example, To select digital channel number: 10-2

1. press numeric key "1" and "0"
2. press the "▶" button
3. press the numeric key "2"

Freezing the Picture

- Press the "FREEZE" button on the remote control to freeze the picture.
The "Freeze" message will appear in the upper right corner of the screen.
- Pressing the "FREEZE" button again will release the picture.

Note: If you freeze a program for purposes other than personal viewing, you may infringe on the program's copyright.



DTV Channel Table Information

*Log on to the website <http://www.antennaweb.org> and select "Choose An Antenna". Enter your address and find the DTV stations airing the EDTV / HDTV signal in your local area and then visit the local station websites for program schedules. Usually the website names are the same as the station's name. For example, DTV station WCBS (channel 56) New York's website is <http://www.wcbs.com> and KCET (UHF channel 59) Los Angeles's website is <http://www.kcet.org>.

However, the most accurate method for locating the local station's website is through their parent Network. For example, to find WCBS New York, check the CBS website. You can also contact the network service center for detailed information about their local DTV program package.

Note: (a) Using the Antenna Web site, you can also get information about choosing the correct type of antenna and the proper direction to point it toward the DTV station you want to watch.

(b) NAB (Association of Broadcasters) has updates on the local DTV stations in operation at <http://www.nab.org/Newsroom/Issues/digitaltv/DTVstations.asp>

Specifications

Specifications

Panel size	42 "
Aspect Ratio	16:9
Pixels	1366 X 768
Dynamic Contrast Ratio	1600:1
H/V(View Angle)	178 (H) / 178 (V)
Gray to Gray Response Time	8 ms

Video/Graphic Processing

PC compatible frequency	30~85 KHz(H) / 50~80Hz(V) Max. 1360x768 @60Hz
Video Compatibility	NTSC
DTV & HDTV Compatability	480i, 480p, 720p, 1080i
Aspect Ratio Adjustment	Full screen, 4:3, 16:9, Panoramic
3D Comb Filter	Y
3 : 2 / 2 : 2 Pull Down	Y
Digital Noise Reduction	ON/OFF, Low, Middle, Strong
Adjustable Color Temperature	Cool, Middle, Warm, User
De-interlacer	Y
VGA Auto Frequency Correction	Y
TV Auto Frequency Detection	Y

Audio Processing

Auto Sound Level Control	Y
Output Watt	25W+25W
Sound Effect	MTS (Mono / Stereo / SAP) EQ1 and EQ2

Input Terminals

TV Tuner	NTSC VHF/UHF tuner x 1 DTV (ATSC) tuner x 1
Video Input(rear side)	Input 1: AV x1, S-Video x1, RL x1 Input 2: AV x1, S-Video x1, RL x1 Input 3: Y, Pb/Cr, Pr/Cr x1, RLx1 Input 4: Y, Pb/Cb, PrCr x1, RLx1
Graphic Input(Rear)	Input 1: RGB D-Sub 15 pin x1 Input 2: HDMI1 (DVI-D) x 1, RL x 1 Input 3: HDMI2 (DVI-D) x 1, RL x 1
Service Port(Rear)	RS-232 mini DIN 6pins x 1

* **NOTE** : Product Specification is Subject to Change without Notice.

Output Terminals

Audio Output(Rear)	Speaker Out	Output 1: Stereo Audio R/L X 1
--------------------	-------------	--------------------------------

Others

Power (Voltage)	100~240 VAC / 50-60 Hz
(Power Consumption)	230W (Reference)
Stand-by	< 3W
Dimensions (W x D x H)	42.7 in x 10.6 in x 34.8 in
Carton Dimensions (W x D x H)	51.2 in x 14.2 in x 38.6 in
Weight	106.9 lbs
Weight w/ stand	119.07 lbs
Gross weight	140.02 lbs

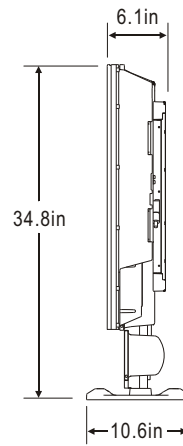
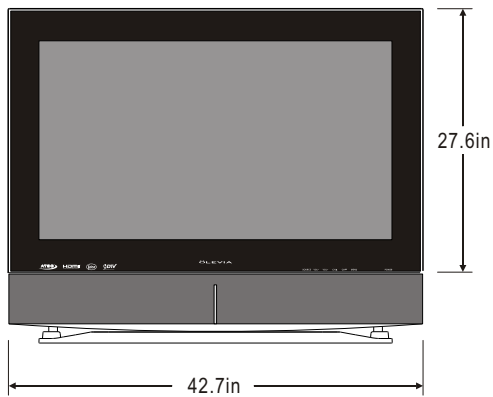
Dimensional drawing

Timing Mode for VGA and HDMI

Source	Resolution	Vertical frequency(Hz)	Horizontal frequency (Khz)	Pixel rate (MHZ)
YPbPr	480p	59.94	31.469	27
	720p	60	45	74.25
	1080i	60	33.75	74.25
VGA	512 x 384	60.147	24.48	15.667
	640 x 350	85	37.861	31.5
		85	37.861	31.5
	640 x 400	56	24.823	21.05
		59	30.296	24.964
	640x480	59	30.295	25.024
		66	35	30.24
		66	34.975	31.34
		66	35	30.24
		72	37.861	31.5
		75	37.5	31.5
		75	39.375	31.5
		85	43.269	36
	720 x 350	70	31.469	28.32
	720 x 400	70	31.469	28.32
		85	37.927	35.5
		87	39.444	35.5
	800 x 600	56	35.156	36
		60	37.879	40
		72	48.077	50
		75	46.875	49.5
		85	53.674	56.25
	832 x 624	74.6	49.725	55
	1024 x 768	86	35.522	44.9
		59	48.193	64
		60	47.699	64.1
		60	48.363	65
		70	56.476	75
		70	56.287	77
		71	57.87	75
	75	60.241	80	

Source	Resolution	Vertical frequency(Hz)	Horizontal frequency (Khz)	Pixel rate (MHZ)
VGA	1024 x 768	75	60.241	80
		75	62.937	84.6
		75	61.08	86
		75	60.023	78.75
		77	62.04	84.4
		85	68.677	94.5
	1152 x 864	70.012	63.851	94.5
		75	67.5	108
	1152 x 870	75.062	68.681	100
	1152 x 900	65.95	61.795	92.9
		66.004	61.846	94.5
		76.047	71.713	105.6
		76.149	71.809	108
	1024 x 1024	60	63.36	89.2
		61.399	65.286	92.9
	1280 x 960	60	60	108
	1280 x 720	60	45	74.25
	1280 x 768	60	48.36	81.631
	1280 x 1024	60	63.981	108
	1366 x 768	60	47.7	85.8
HDMI	1080i	60	33.75	74.25
	720P	60	45	74.25
	480P	59.95	31.8	25.18

Pixels Policy

Syntax's D.O.A. Policy for LCD TVs for Defective Pixels on LCD Panels

(Applicable to the LCD TV sold within USA & Canada only)

Syntax™ LCD TVs are evaluated at a distance of approximately 50 centimeters (approximately 20 inches) between the LCD panel and the eyes of the user at a 90 degrees viewing angle. All LCD panels have been tested to ensure they comply with our factory standards. Our evaluation is based on the number of defective pixels and the distance between any two defective pixels. Bright dots are dots that appear bright and unchanged in size when a LCD TV screen displays under a black pattern; dark dots are dots that appear dark and unchanged in size when a LCD TV screen is displayed under pure red, green, or blue patterns ("defective pixels"). Adjacent dots are dots located directly next to each other.

Customers are required to check their LCD panel immediately after purchase. To identify defective pixels, the LCD panel should be examined under normal operating conditions as mentioned above, preferably in its native display resolution, and with a 90 degrees viewing angle.

A LCD TV will be considered dead on arrival (D.O.A.) with regards to defective pixels on the LCD panel when any one of the following criteria is met:

- A total of 7 defective pixels including both bright dots and dark dots are present (the typical 30" LCD Television screen has 16.7 million pixels), or
- 2 or more pairs of adjacent bright dots are present, or
- 3 adjacent bright dots are present, or
- 3 adjacent dark dots are present.

In view of customers' concerns about dead pixels, Syntax would like to address that defective pixels are not ultimately avoidable with the current LCD industry standard panel manufacturing processes. We always strive to improve our technology and minimize the chance of occurrence of defective pixels by applying strict screening processes in our factory production processes. However, Syntax cannot guarantee that a return unit to our customers will be 100% free of defective pixels.

For questions, please call our toll free service number in the USA at 888-SYNTAX-8.

"At SyntaxGroups, a satisfied customer is our most important focus."

Glossary

3:2 pull down - Process of converting 24 frames per second film to video by repeating one film frame as three fields, then the next film frame as two fields.

1	1	1	2	2	1	1	1	2	2
---	---	---	---	---	---	---	---	---	---

480I - 480 lines of display every 1/60 of a second; image is displayed by interlace scanning. See also Interlaced

480P - 480 lines of display every 1/60 of a second; image is displayed by progressive scanning. See also Progressive.

720P - 720 lines of display every 1/60 of a second; image is displayed by progressive scanning. See also Progressive.

1080I - 540 lines of display x 2 every 1/30 of a second; image is displayed by interlace scanning. See also Interlaced

16:9 - Aspect ratio under Hi Def. and theater movie formats. Also known as widescreen; see Aspect Ratio

4:3 - Aspect ratio under SDTV; see Aspect Ratio

Active Matrix TFT (Thin Film Transfer) - A type of display technology where the three primary colors are modulated. Results in better contrast ratios suitable for video.

Alarm - Feature on the Syntax Olevia models. Allows the unit to power on from the stand by mode.

Alarm Time - Time specified as to when the unit will power on. See Alarm.

Aspect Ratio - The ratio of an image according to the width and height of a picture.

ATSC - Advanced Television Systems Committee; international, non-profit organization that is committed to developing standards for digital television.
Reference: <http://www.atsc.org>

Bezel - Refers to the plastic or metal frame that acts like a shell around the LCD glass.

Backlight - Refers to the component, that lights up the LCD display.

Balance - Feature on the OSD for the Syntax Olevia models that adjust the left and right sound output from the speakers.

Background - Feature on the OSD for the Syntax Olevia models, which allows the user to change the OSD background, display to transparent or opaque.

Brightness - The measurement of color that is illuminated. Colors range from black to white.

CATV - Community Antenna Television (Cable Television)

Channel Favorite - Feature on the OSD for the Syntax Olevia models that allows the user to scroll through a defined list of channels that the user sets up.

Channel Edit - Feature on the OSD for the Syntax Olevia models that allows the user add or delete a channel.

Channel Source - Feature on the OSD for the Syntax Olevia models that lets the user select the source of their channels. Select TV for antennae or CATV for cable television.

Channel Auto Scan - Feature on the OSD for the Syntax Olevia models that when initiated, will determine which channels are available and which are not. If a desired channel is not accessible, you can add the channel in manually. See Channel Edit.

Channel Fine Tune - Feature on the OSD for the Syntax Olevia models that enables the user to tune the channel for better reception.

Chroma - (Chrominance) Refers to the color characteristics of a video signal.

CC - Closed Caption

Color - The term refers to the amount of color present. This varies between each user, as each person perceives colors differently.

Color Temperature - Feature on the OSD for the Syntax Olevia models that enables warm, normal or cool color settings. Warm emphasizes red, cool emphasizes blue, and normal doesn't emphasize any of the primary colors. This setting may affect each person individually depending on how color is perceived.

Comb Filter - A filtering system designed to removal unwanted artifacts by rejecting certain frequencies while permitting others.

Component - A three RCA type input that uses high quality cables (one for brightness, and two for color). Process increases bandwidth resulting in more color information to be carried to the TV producing a more accurate picture.

Composite - Also known as CVBS, Technology that permits the combination of color information and brightness under one wire. A single video signal that carries both brightness and color information are contained in a single wire.

Contrast - Difference in luminance between the white and black colors.

CRT - Cathode Ray Tube.

DB15 - Also referred to as VGA; See VGA

De-Interlace - Process of converting an interlaced video signal.

Display Area - The perimeter of the LCD glass the image is displayed on. See Video Resolution

Dual Link - See Single Link; Supports a maximum bandwidth of 2 x 165 MHz (1920 x 1080 @ 60 Hz, 1280 x 1024 @ 85 Hz).

DVI - Digital Video Interface Describes the technology that is used to take full advantage of a signal when paired with a high-end video card and flat panel displays

DVI-A - Digital Video Hi-Resolution Analog

DVI-D - Digital Video Interface Digital; Cable is used for direct connection from one digital source to the TV; See DVI

DVI-I - Digital Video Interface Integrated; Cable that supports analog and digital signals; See DVI

DTV - Digital Television

Factory Default - Feature on the OSD for the Syntax Olevia models that resets all menu options to factory default.

F-Connector - The standard connector found on video equipments that coaxial cables connect to.

Flat-Panel Display - ultra thin displays, usually found in notebooks are now entering the TV appliances sector as new technology enables wider/larger screens.

Frame - A complete picture that includes both even and odd lines. 30 video frames are present in 1 second.

Gain - Describes the amplification level of a particular signal.

HDCP - High bandwidth Digital Content Protection

HDTV - 1.High Definition Television 2. Designates as the unit having a built in ATSC tuner to decode High Definition signals (720P/1080I).

HD-Ready - A unit that supports the High Definition displays (720P/1080I) with the help of a Set-Top Box.

Horizontal Resolution - Refers to the number of vertical black and white lines defined along a horizontal line.

IR - Infrared

Input - term used in the On Screen Display

Interlaced - Images are the result of lines of data reassembled. Interlaced refers to the process of an image's odd lines reassembled from top to bottom taking about 1/60 of a second, before reassembling the even lines which results in a full picture. Antonym: Progressive

Language - Feature on the OSD for the Syntax Olevia models that enables the OSD to be read in different languages.

LCD - Liquid Crystal Display

LCoS - Liquid Crystal on Silicon

LED - Light Emitting Diode

Luminance - refers to the brightness of an image.

Lux - 1 Lux = 1 footcandle; measurement of brightness

Moiré - A visual illusion in which a succession of parallel curved lines produces a pattern to the naked eye, but does not really exist. Otherwise known as the moiré effect.

NCTA - National Cable Television Association

Noise reduction - Feature on the OSD for the Syntax Olevia models that enables channels from the tuner box to reduce noise displayed on the LCD unit.

NTSC - National Television systems Committee

OSD - On Screen Display; brought up by pressing the menu button on the TV or the Remote.

Over Scanning - An image displayed is larger than the display area

PAL - Phase Alternating Line

Parental Control - The ability to block access to specified content from an unsuitable audience.

PIP - Picture in Picture; feature that enables one source to be displayed on top of another source.

Pixel Resolution - Refers to the number of rows horizontal and vertical that produces the image.

PIP - Picture in Picture; Allows an image to be displayed in front of another image.

Plug and Play - Describes the hardware or software that is installed and does not require any configuration before using.

Progressive - An image or lines of data that is reassembled from top to bottom sequentially.

Antonym: Interlaced

RGB - Red, green & blue These primary colors provide the basis for many different colors.

Refresh Rate - Refers to the maximum number of frames that the monitor can display per second. Usually measured in hertz.

Saturation - The amount of a particular color present in an image.

SCART - An industry standard for interconnecting audio-video equipment developed by Peritel. Usually associated with PAL video equipment.

SDTV - Standard Definition Television usually in 480I/P format.

SECAM - Sequential Color with Memory or Sequential Couleur Avec Memoire

Set-Top-Box - box that is capable of receiving and decoding digital transmissions (i.e. High Definition Cable Box, Digital Cable box).

Sharpness - Tries to artificially enhance the edges of a picture.

Single Link - supports a maximum bandwidth of 165 MHz (1920 x 1080 @ 60 Hz, 1280 x 1024 @ 85 Hz).

Split screen - Feature that places two images side by side.

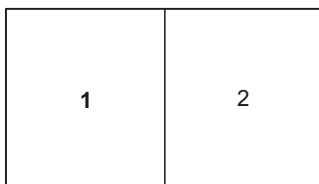

Swap - Button featured on the Olevia remote. Used in the POP3 or PIP12 views to swap the sub viewable boxes with the main viewable box.

Tint - Adjusts the whiteness level within the color. Similar to Hue.

Under- scanning Term used where the image displayed is smaller than the display area.

Up convert - Process of converting a 480P/I signals to 720P or 1080I.

V-Chip - Chip that controls access to forbidden content specified by an adult.

VGA - 1. Video Graphics Array (DB15) 2.

Video Display - Refers to the display resolution

Video Resolution

Aspect Ratio 4:3		Aspect Ratio 16:9	
VGA	640 x 480	WXGA	1280 X 800
SVGA	800 x 600	SXGA	1280 X 1024
XGA	1024 x 768	WXGA+	1400 X 1050
QVGA	1280 x 960	WSXGA	1680 X 1050
SXGA+	1400 x 1050	WUXGA	1920 X 1200
UXGA	1600 x 1200	QSXGA	2560 X 2048
QXGA	2048 x 1536		
QSXGA+	2800 x 2100		
QUXGA	3200 x 2400		

Viewable Angle - Angle at which the screen is still viewable.

Widescreen - See 16:9

YCbCr - Used often with standard interlaced video equipment. See Component

YPbPr - Used often with progressive video equipment. See Component